

November 21st, 2012

Lecture

Functional Carbon Materials for Energy and Environmental Devices

Yoon, Seong-Ho, Jin Miyawaki

IMCE, Kyushu University

6-1 Kasuga-Koen, Kasuga, Fukuoka, Japan 〒 816-8580

yoona@cm.kyushu-u.ac.jp



Application of carbon materials

Electric and Heat Conductions

- Conductor and Semi-conductor

Energy Storage

- Battery anode
- Super capacitor
- Gas storage

Environmental Protection

- Activated surface

Mechanical Reinforcement

High Temperature Materials

Applications of Carbons

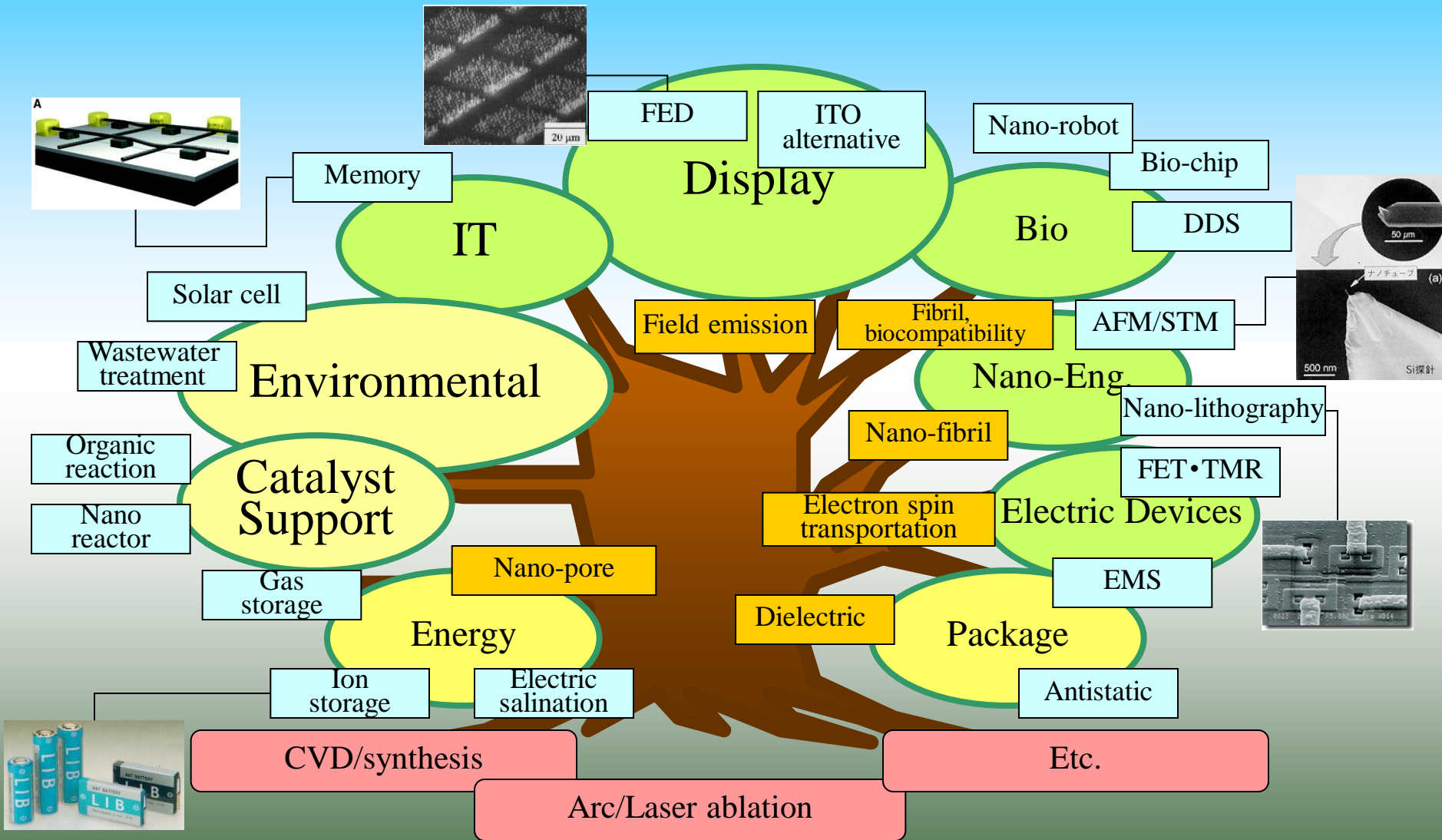

Characteristics of carbons

- **Thermal stability**
- **High thermal and electric conductivities**
SWNT, Diamond : 4000 W/mK, K-11
carbon fiber: 1100 W/mK
- **Small heat expansion**
- **High thermal shock properties**
- **High chemical stability**
- **Abrasion and lubricant properties**
- **High mechanical properties**

Thermal characteristics of carbons

■ 黒鉛の温度依存性

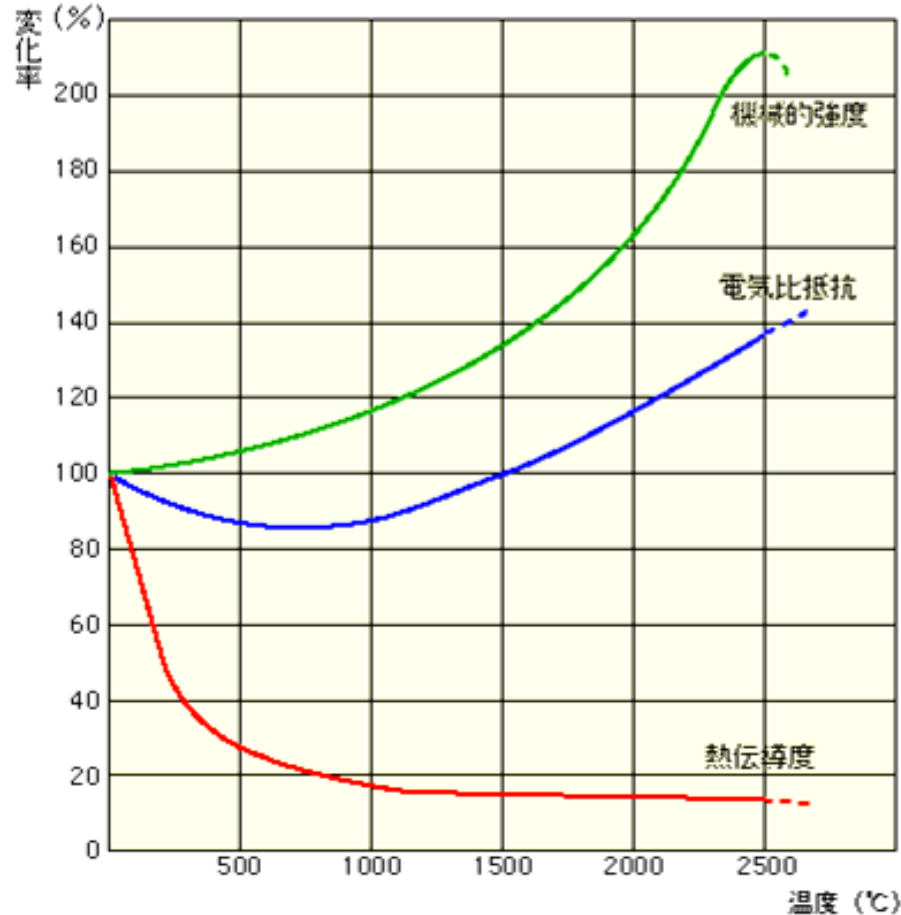

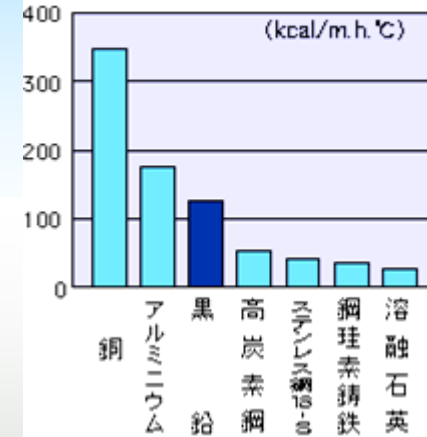

■ 各種材料の熱伝導度

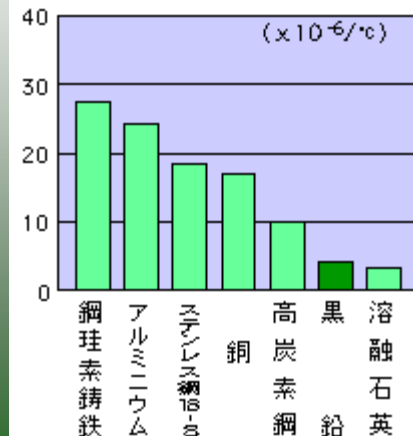

■ 各種材料の熱膨張係数

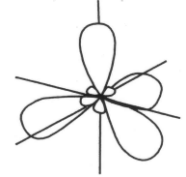
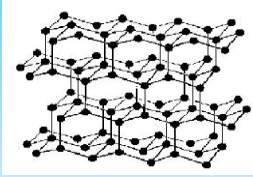
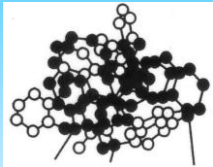
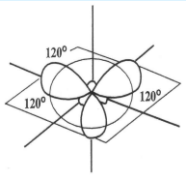
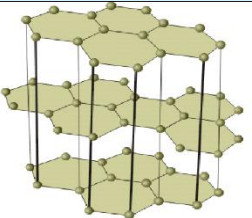
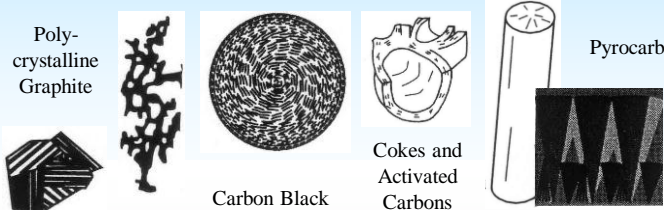

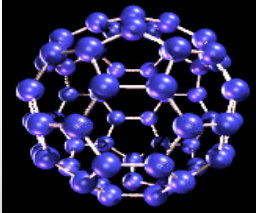
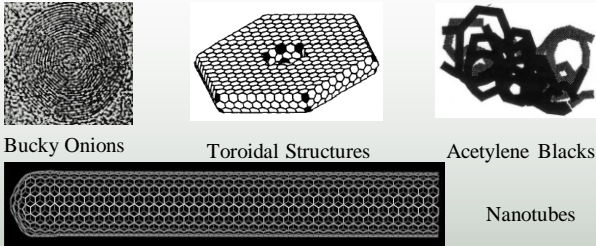
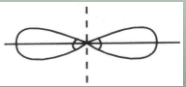
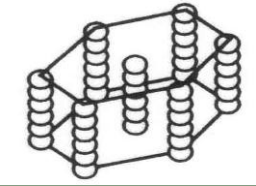
Bonding Hybridization	Allotropes	Derived and Defective Forms
 <p data-bbox="417 382 467 411">SP³</p>	 <p data-bbox="620 386 795 411">Cubic diamond</p>	 <p data-bbox="1070 379 1306 404">Diamond-like Carbon</p>
 <p data-bbox="417 665 467 694">SP²</p>	 <p data-bbox="600 675 830 699">Hexagonal graphite</p>	 <p data-bbox="929 472 1016 546">Polycrystalline Graphite</p> <p data-bbox="1128 636 1248 661">Carbon Black</p> <p data-bbox="1290 589 1377 658">Cokes and Activated Carbons</p> <p data-bbox="1508 486 1615 511">Pyrocarbons</p> <p data-bbox="1418 665 1537 689">Carbon Fibers</p>
 <p data-bbox="355 882 581 951">SP^{2+ε} rehybridization</p>	 <p data-bbox="658 943 774 968">Fullerene</p>	 <p data-bbox="909 858 1035 882">Bucky Onions</p> <p data-bbox="1112 865 1277 889">Toroidal Structures</p> <p data-bbox="1354 865 1499 889">Acetylene Blacks</p> <p data-bbox="1392 922 1489 946">Nanotubes</p>
 <p data-bbox="417 1143 467 1172">SP¹</p>	 <p data-bbox="672 1182 774 1206">Carbyne</p>	<p data-bbox="919 1015 1605 1186">Ref.) Bourrat, X. Structure in Carbons and Carbon Artifacts. In: <i>Sciences of Carbon Materials</i>. Marsh, H.; Rodriguez-Reinoso, F., Eds., Universidad de Alicante, 2000. pp1-97.</p>

Carbon Allotropes



図-1 炭素の混成軌道

表-1 各種炭素-炭素結合の結合解離エネルギーと結合距離¹⁾

化合物	結合解離エネルギー (kcal/mol)	結合距離 (Å)
H ₃ C-C ₃ H	88	1.53
H ₂ C=C ₂ H	163	1.34
HC≡CH	198	1.21

表-2 炭素同素体の種類³⁾

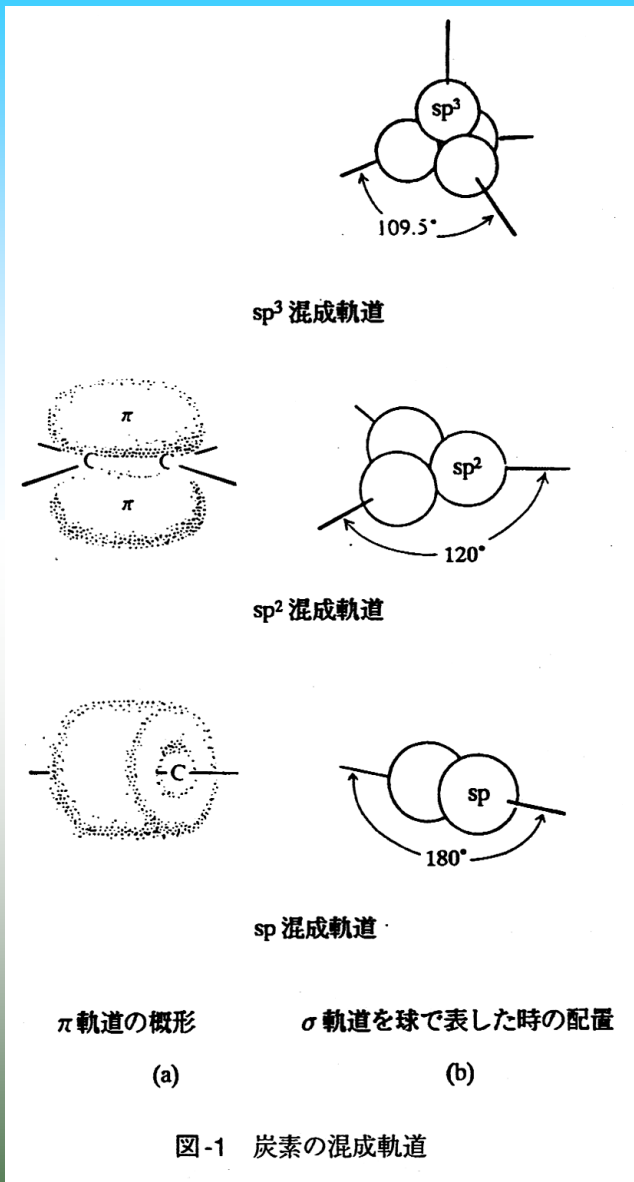
結合の種類	配位数	炭素同素体
sp	2	カルビン (ポリイン, クムレン)
sp ²	3	グラファイト (六方晶, 菱面体晶) フラーレン (C ₆₀ , C ₇₀ , バックキチューブなど)
sp ³	4	ダイヤモンド (立方晶, 六方晶, 菱面体晶*) ダイヤモンド多形体 (6H, bc-8*など) ダイヤモンドライクカーボン (DLC), i-カーボン
イオンまたは 金属的	6	単純立方晶*, β-スズ型*
	8	体心立方晶*
	12	面心立方晶*, 六方最密充填*

* 実!

表-4 IV族sp³立方晶体の性質⁶⁾

性質	ダイヤモンド	β-SiC	Si
格子定数 (Å)	3.567	4.358	5.430
密度 (g/cm ³)	3.515	3.216	2.328
熱膨張率 (×10 ⁻⁶ /°C)	1.1	4.7	2.6
融点 (°C)	4000	2540	1420
バンドギャップ (eV)	5.45	3.0	1.1
キャリア移動度 (cm ² /(V·S))			
電子	2200	400	1500
ホール	1600	50	600
熱伝導率 (W/(cm·K))	20	5	1.5
硬度 (kg/mm ²)	10000	3500	1000

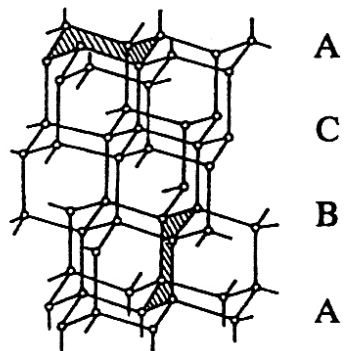

立方晶ダイヤモンド

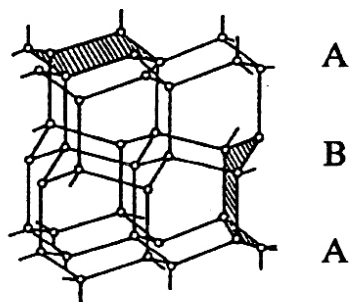

六方晶ダイヤモンド

図-2 ダイヤモンドの構造⁵⁾

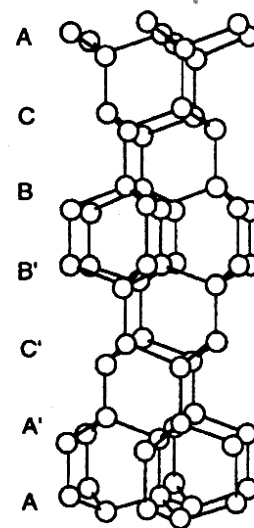

6H型ダイヤモンド
(a)

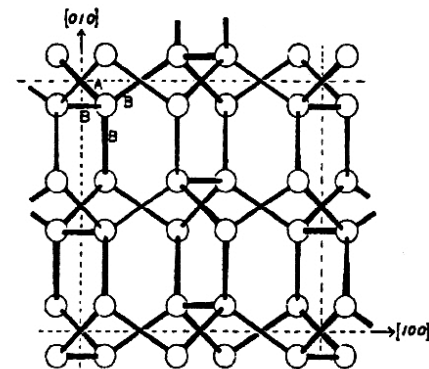

bc-8型ダイヤモンド
(b)

図-3 6H型およびbc-8型ダイヤモンド多形体の構造^{5), 8)}

Molecular structures of graphite

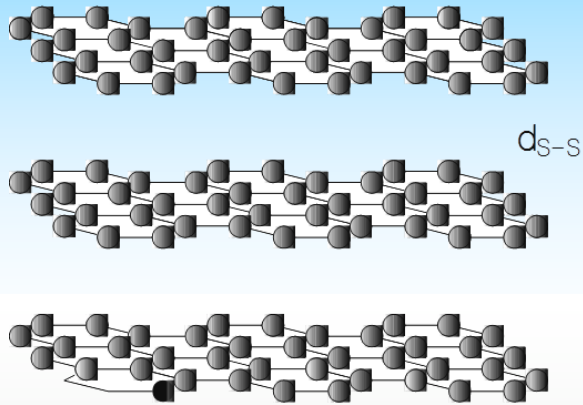

(a) Basic Structure of Graphite

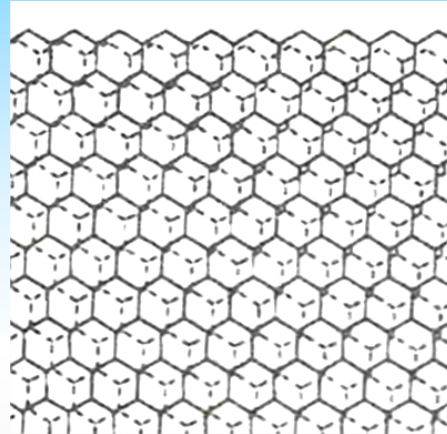

(b) Turbostratic structure (low crystallinity)

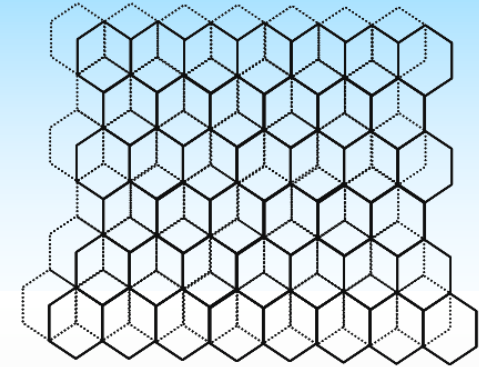

(c) Graphitic structure (high crystallinity)

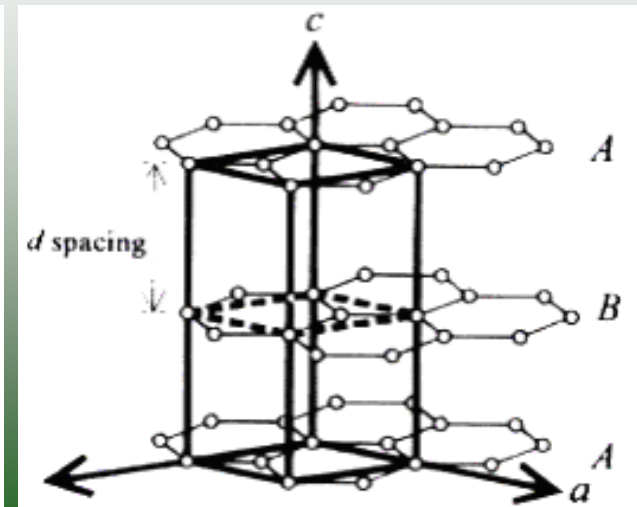
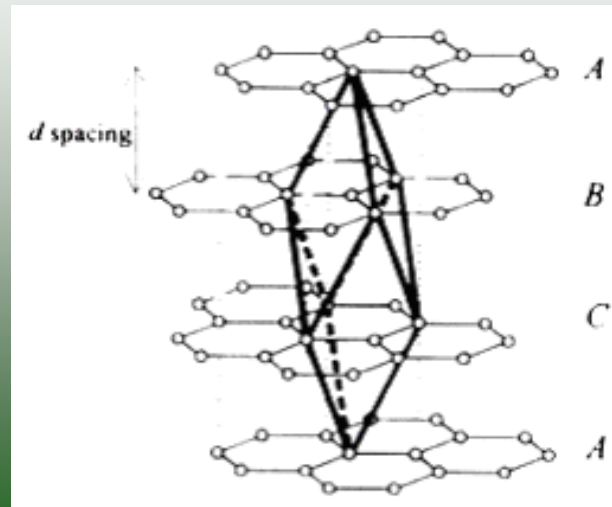

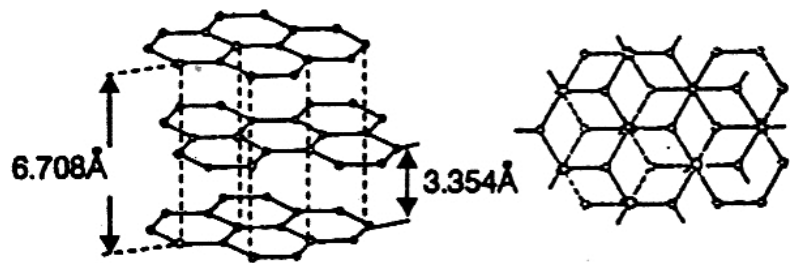

黒鉛

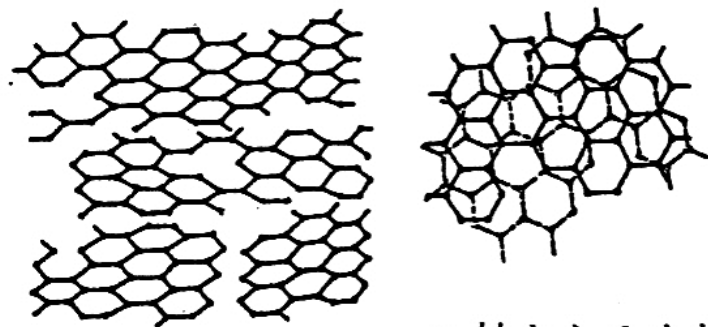

乱層構造

C軸からみた場合

図-3 黒鉛と乱層構造の積層状態の違い



図-2 六方晶系黒鉛の格子面



六方晶グラファイト

(a)

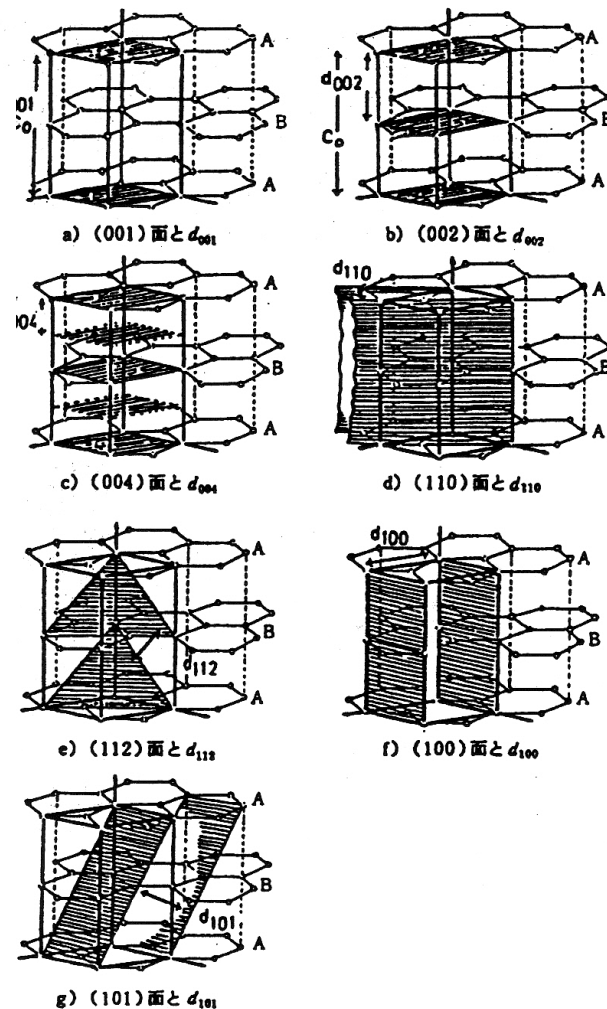
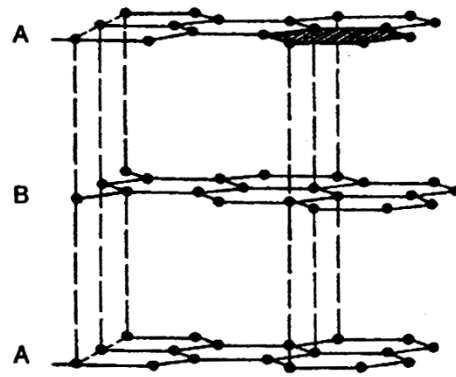
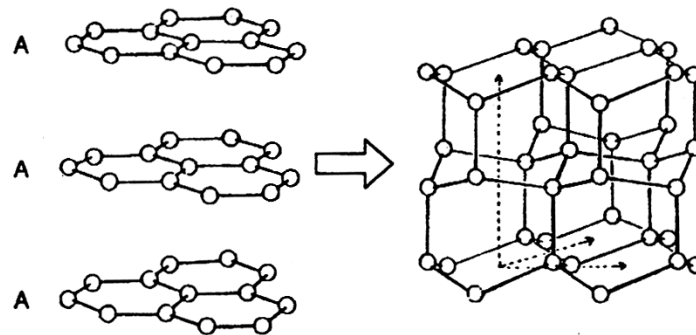

カーボン VII

(b)

六方晶ダイヤモンド

(c)

図-4 グラファイトの構造およびダイヤモンドへの転換イメージ¹²⁾

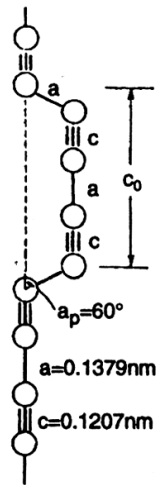

クムレン

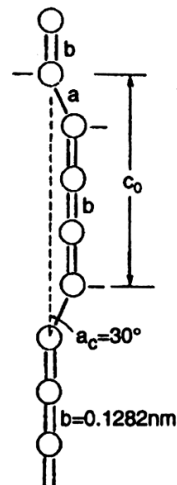

ポリイン

(a)

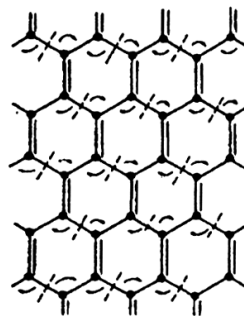
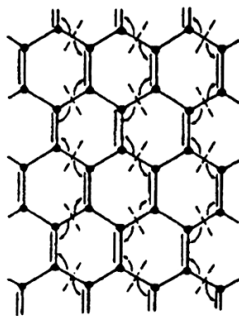

グラファイト面内の一重結合の開裂イメージ

(b)

図-6 カルビンの構造およびグラファイト面内一重結合開裂イメージ2)



図-7 カルビン同族体の鎖内炭素数 n と C_0 パラメータ (図-6 参照) との関係2)



(a) 1964年に提案された相図

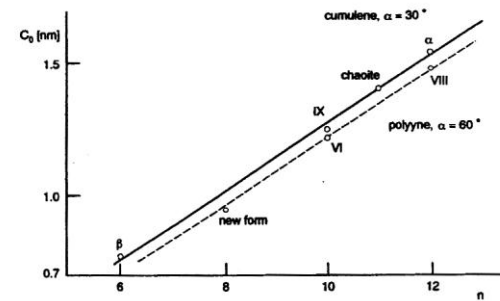
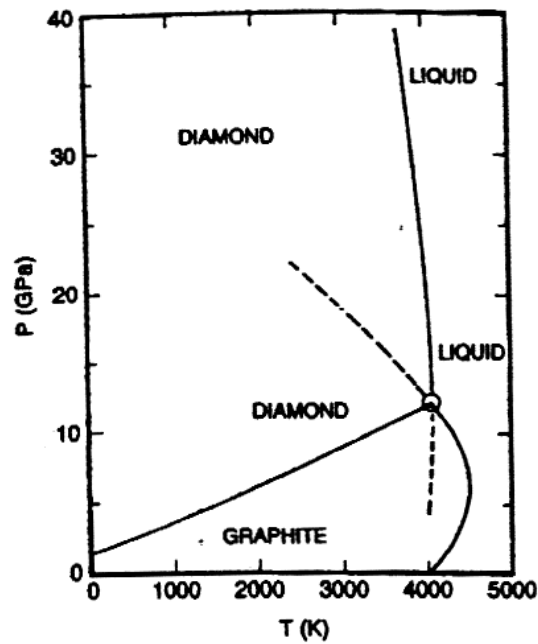
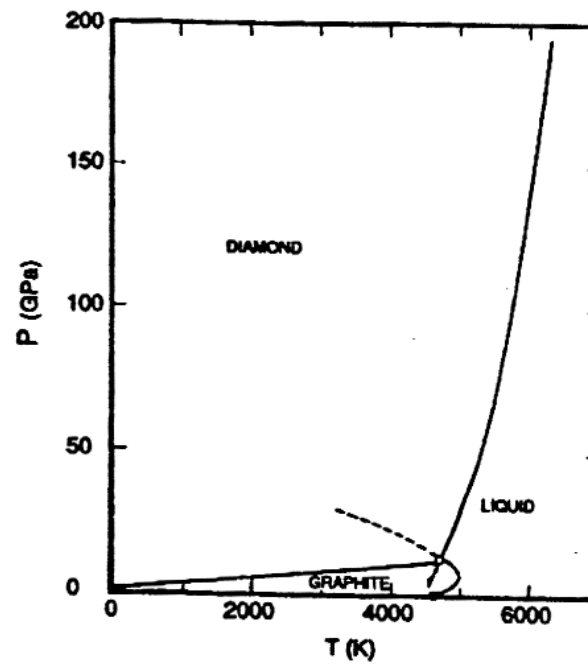

(b) 1989年に提案された相図

図-8 Bundyによって提案された炭素の相図²⁷⁾

Conventional Fossil Fuels

Petroleum Exploration and Production, Refining of Heavy Fraction to Very Clean Fuel

Coal Clean Coal Technologies
Efficient Combustion
Gasification
Liquefaction

Natural Gas Transportation

LNG or Pipe Line

GTL: Small Resources

Price and Cost : Ultimate Recoverable Quantity



化石燃料の将来

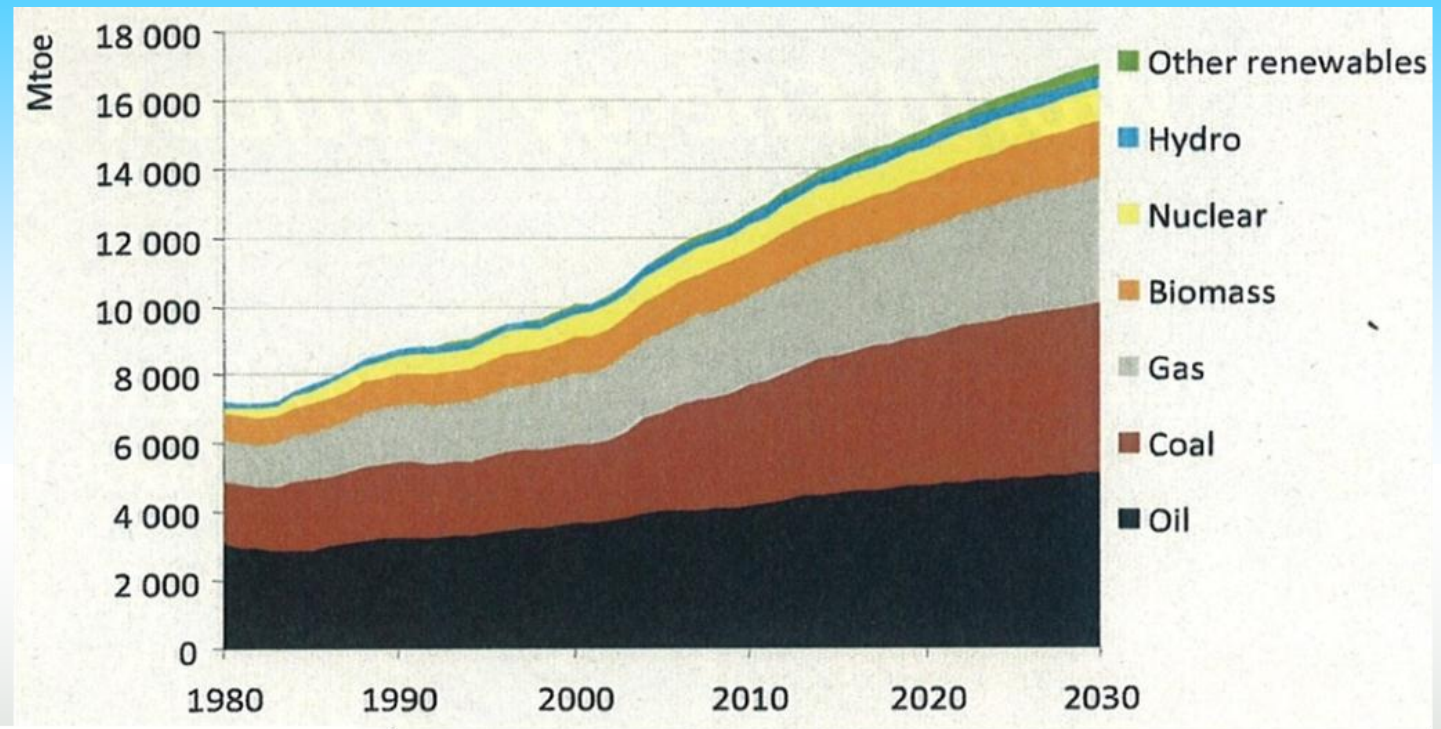

	1980	2000	2006	2015	2030	Annual average increase rate 2006-30
Coal	1788	2295	3053	4023	4908	2.0%
(US)			551	580	633	0.6%
(China)			1214	1898	2441	4.0%
(India)			223	315	579	6.0%
Petroleum Oil	3107	3649	4029	4525	5109	1.0%
Gas	1235	2088	2407	2903	3670	1.8%
Nuclear Power	186	675	728	817	901	0.9%
Hydraulic Power	148	225	261	321	414	1.9%
Biomass	748	1045	1186	1375	1662	1.4%
Other Renewables	12	55	66	158	350	7.2%
Total	7223	10034	11730	14121	17014	1.6%

Approx. 45% increase

Three countries - U.S., China, and India - account for 75% in 2030



炭素材料原料

Raw materials

Coal tar

Polymer: Thermosetting and thermoplastic

Heavy oil and residues

Biomass

Precursor

- Pitches: CF, ACF, MCMB, Ball type AC, Binder pitch, Additives
- Polymer: AC, ACF, Glassy carbon, CF
- Cokes: Electrode, Capacitor, Battery anode, AC, Additives
- Char: AC, Additives, Reducer for Solar cell



From fossil fuel to functional carbons

Carbonaceous resources

Side products

Advanced Carbon Materials for Energy Saving, Storing, And Environmental Protections and Improvements

Effective conversion and utilization of fossil fuels and their residues

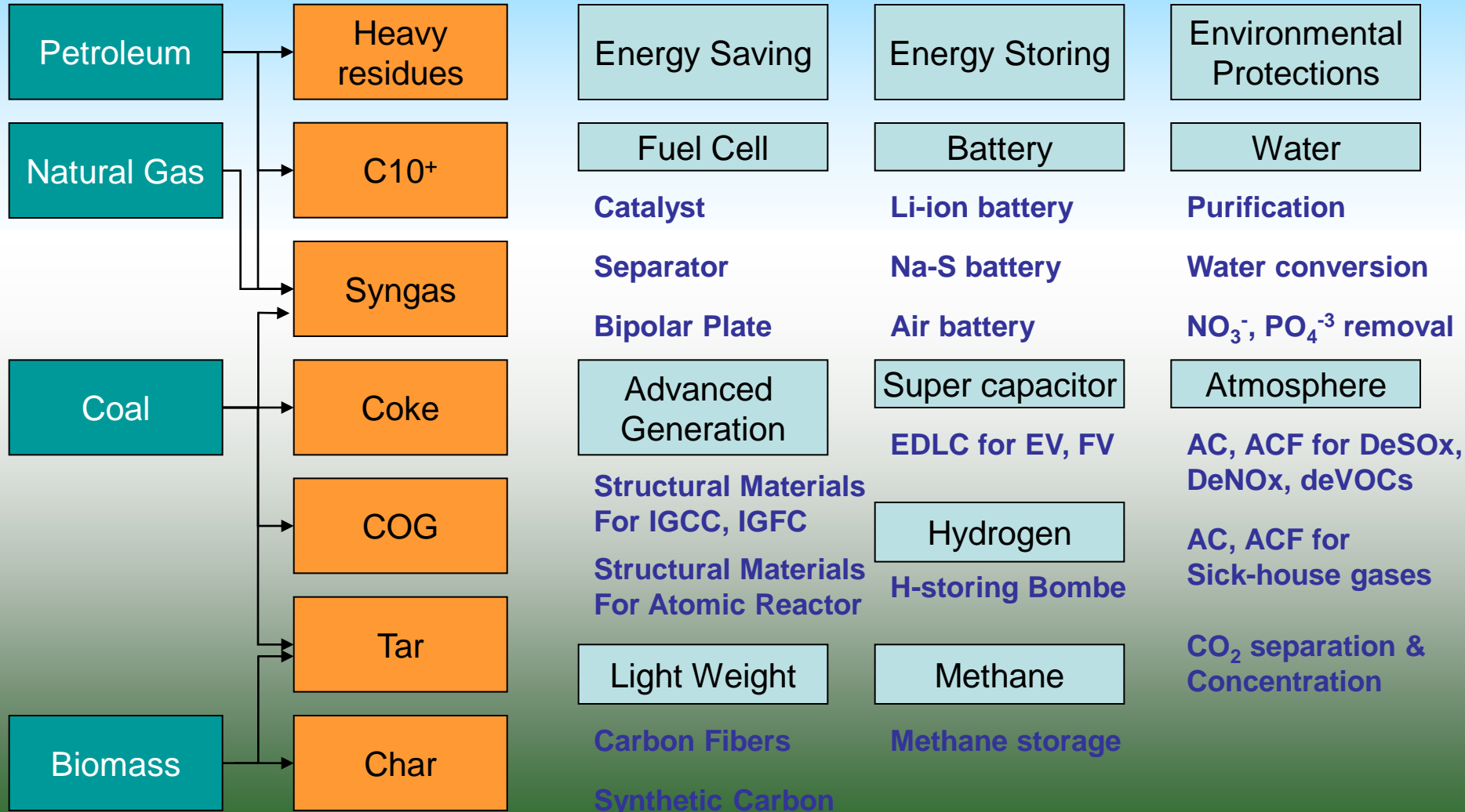

ピッチ系高性能炭素繊維

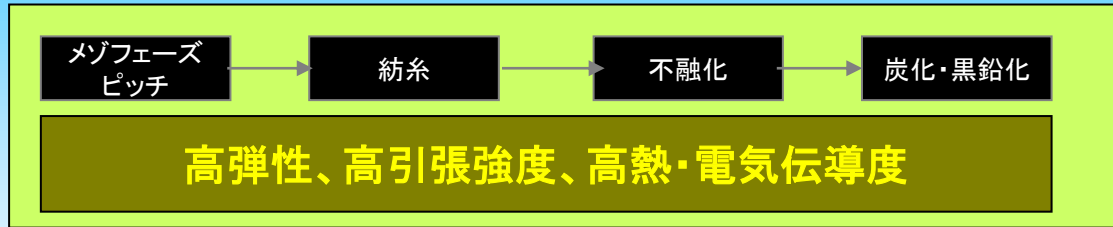

問題点: 低圧縮強度 > 複合材料使用制限

原因: ドメイン(プリット構造)の大きさ・均一さ

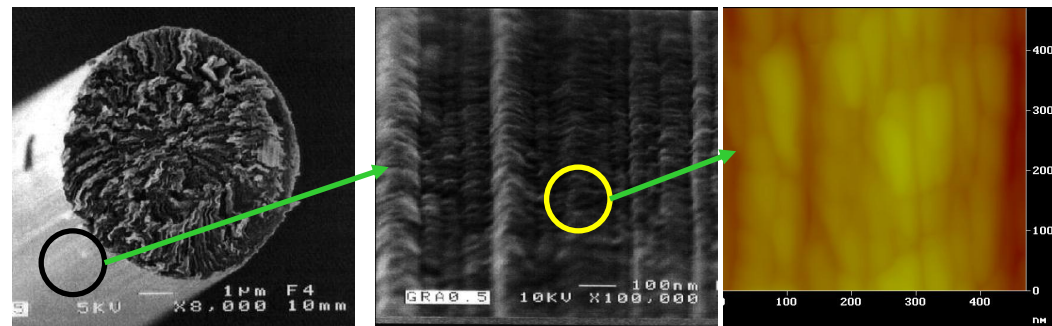

Pleat構造 > 均一・縮小 > 圧縮強度向

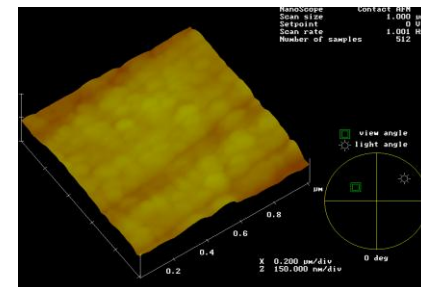
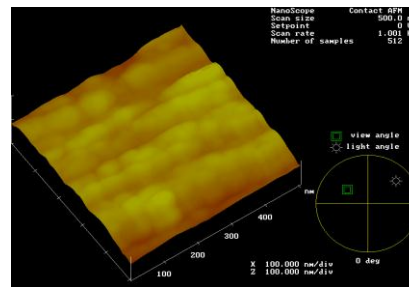

Classification of Carbon Fiber

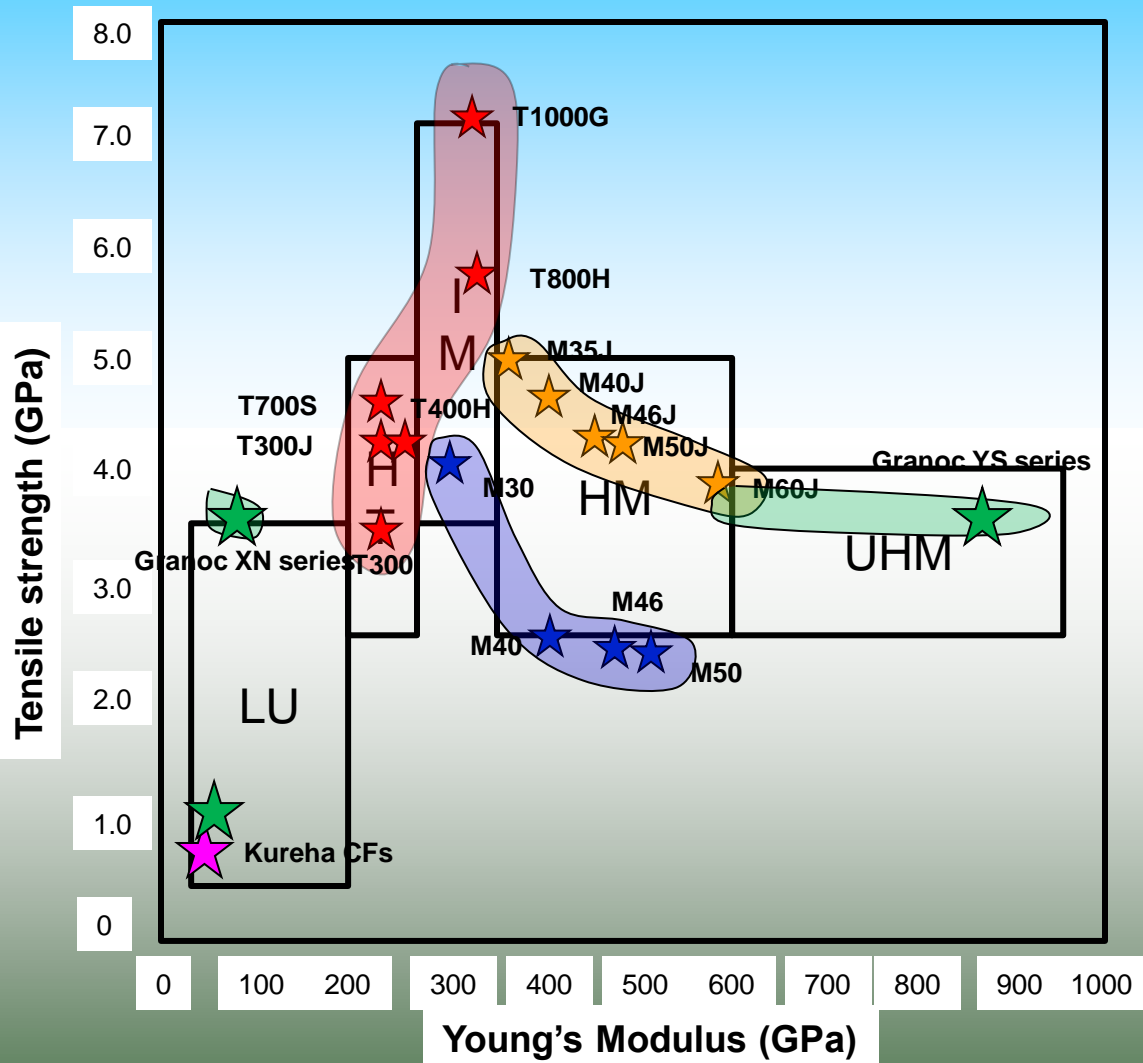

- Ultra High Modulus Type (UHM)
Young's Modulus > 600GPa
Tensile Strength > 2500MPa

- High Modulus Type (HM)
Young's Modulus : 350~600GPa
Tensile Strength > 2500MPa

- Medium Modulus Type (IM)
Young's Modulus : 280~350GPa
Tensile Strength > 3500MPa

- Standard Modulus Type (HT)
Young's Modulus : 200~280GPa
Tensile Strength > 2500MPa

- Low Modulus Type (LM)
Young's Modulus < 200GPa
Tensile Strength < 3500MPa

Carbon Fiber

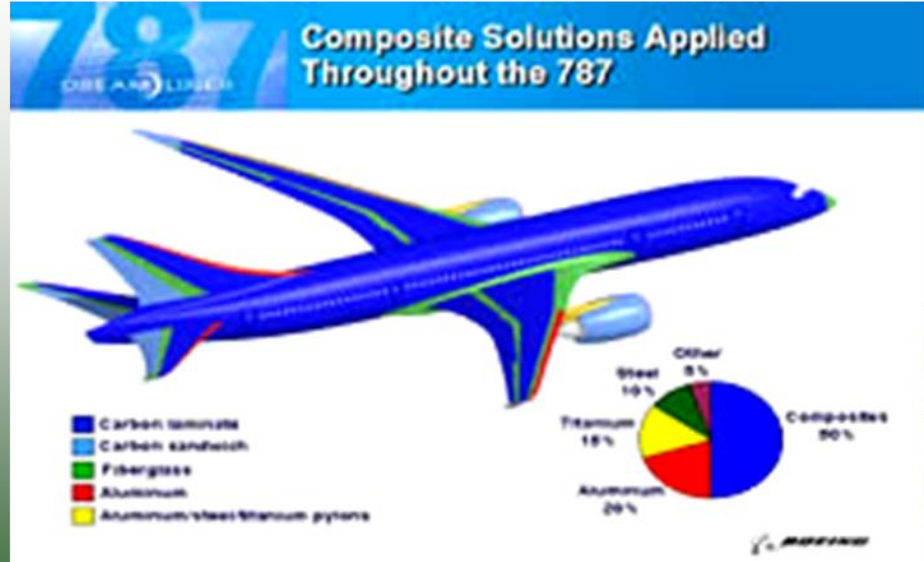

宇宙航空研究開発機構 提供

宇宙航空研究開発機構 提供



CFs for Construction



Windmill



Wind power generation which has become popular recently is expected to require bigger and bigger blades to have higher and higher output capacity for each unit. In order to support big size blades, use of CFRP becomes vitally necessary. And **as the material for high speed rotating body for fly wheels which are attracting public attention as a technology to store energy effectively based on theory of top spinning, use of CFRP is becoming popular.**

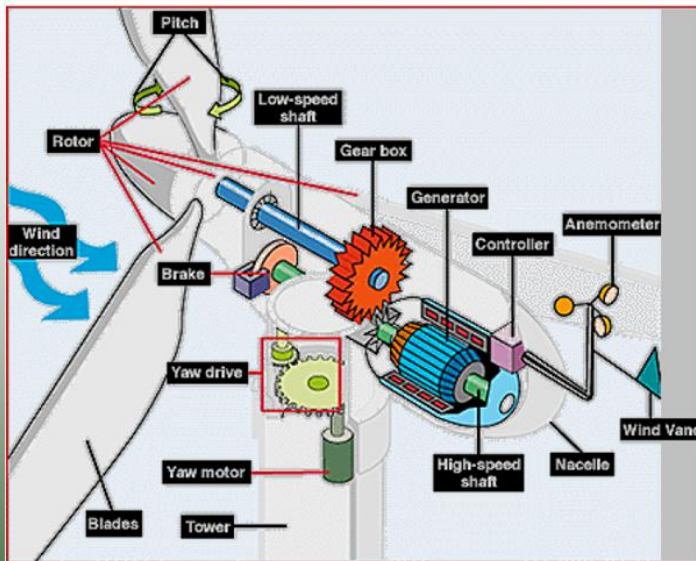

Carbon is key element for Batteries !!

① Li-ion



[High capacity]

(+) : LiCoO_2

(-) : **Carbon(Graphite)**

Conductor : **Carbon**

② Dry Battery



[Cheap]
[Easy Available]

(+) : MnO_2

(-) : Zn

Conductor : **Carbon**

③ Ni-MH



[High power]
[Total balance]

(+) : $(\text{Ni-Co})(\text{OH})_2$

(-) : $\text{Mm}(\text{Ni-Mn-Al-Co})_5$

substrate: Nickel and **Carbon**

Research background : Battery Road

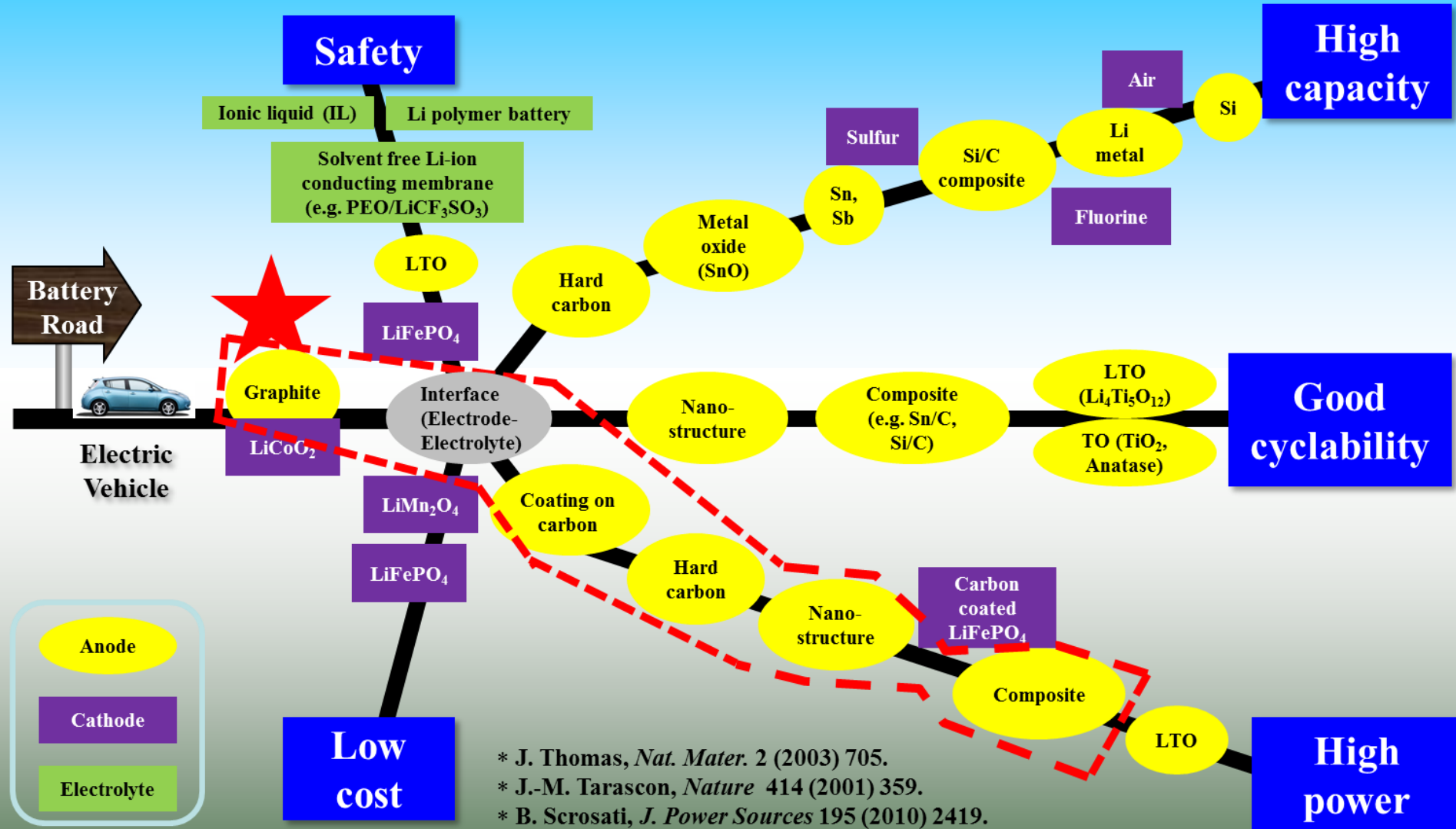

Carbons for Battery, Capacitor, Atomic and Coal Power Plants

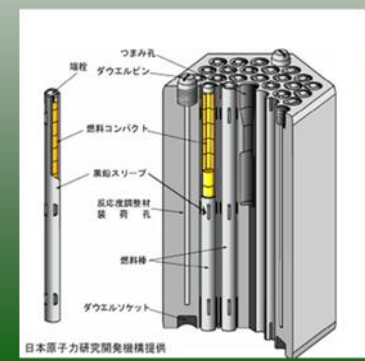
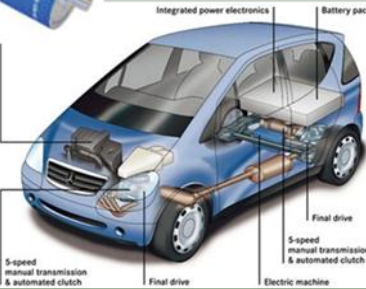
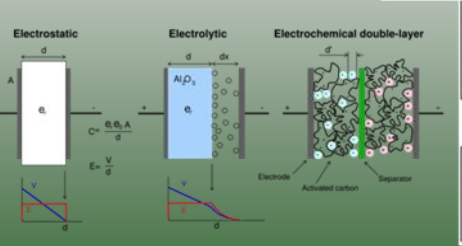
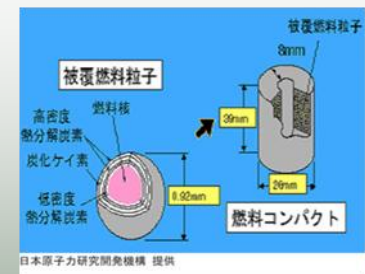
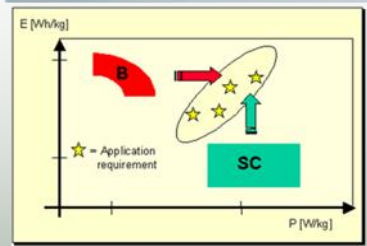
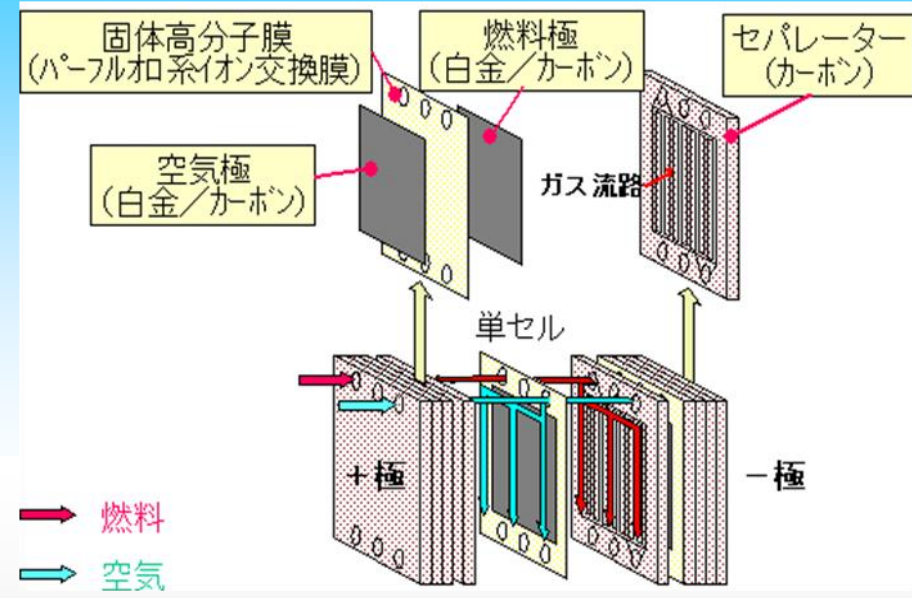
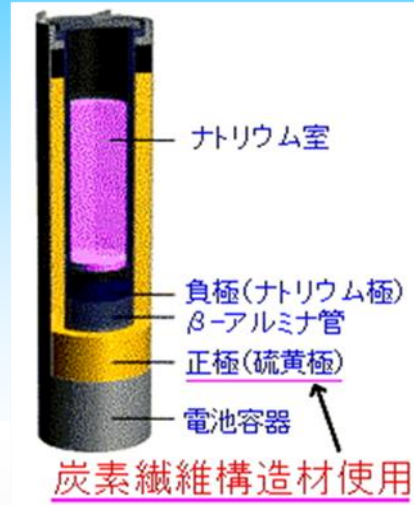
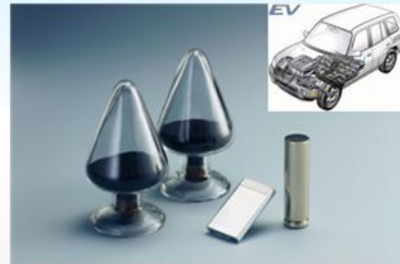

Small fuel cells

DMFC for portable and mobile applications



NEC



TOSHIBA



YAMAHA
Thrilling. Not. Just.



DaimlerChrysler

DMFC



Vectrix



SFC



Semi-conductors



Tray for Wafer : CFRP composites



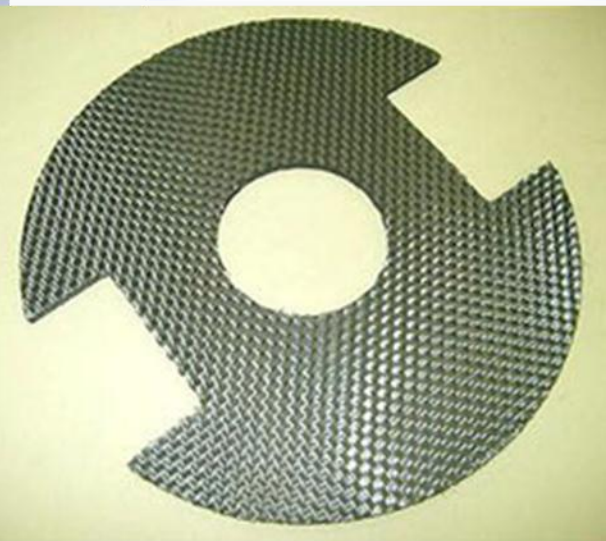
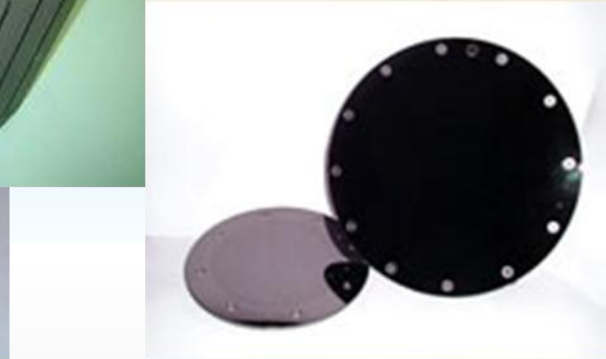

Carbon blacks

Activated Carbons

Carbons for Nuclear

ガラス炭素 (Glassy Carbon)

Resin

硬化

熱処理

加工・後処理

熱・電気伝導性、耐腐食性、高強度、ガス不浸透性

問題点例) 放電加工用電極 >> 半導体 Wafer 上の汚れ

原因: 加熱放電時熱振動によるマイクロドメイン粒子の落ち

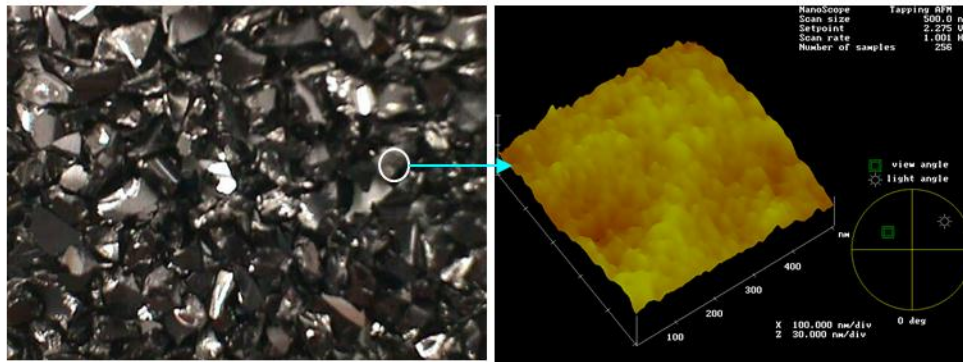

STRUCTURE

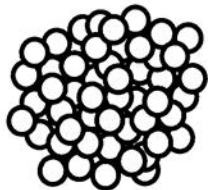

Microgel

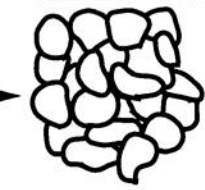

Pseudo-Fused State

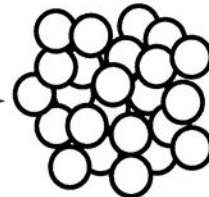

Microdomain

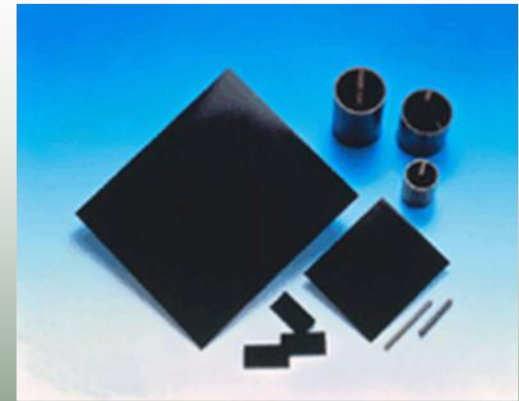

- 高純度の炭素製品>金属系不純物元素による汚染なし
- プラズマによる材料消費を少なく、長寿命
- フッ硝酸で、洗浄しても材料自体の消費なし

ピッチ系活性炭素繊維

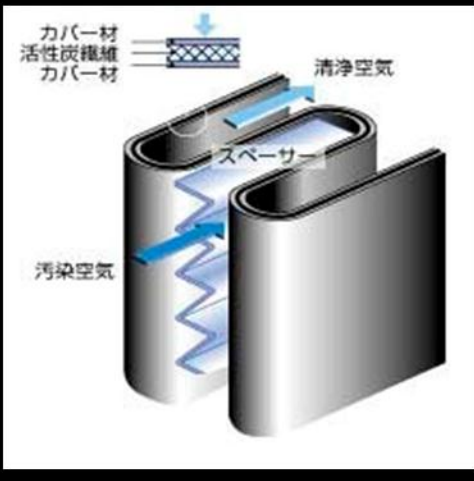
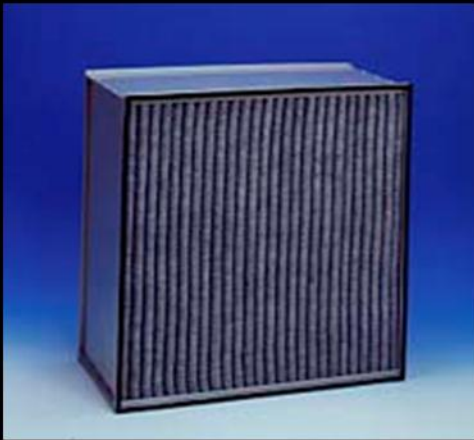
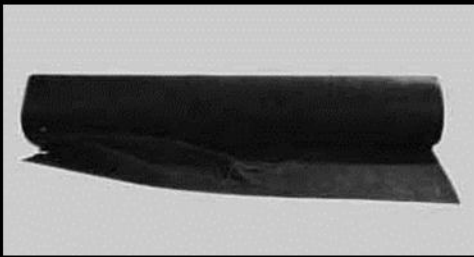

等方性
ピッチ

紡糸

不融化

活性化

高表面積、ミクロポア、繊維状、導電性

問題点: 吸着量、連続吸着、選択性

原因: ポア構造、大きさ、表面特性

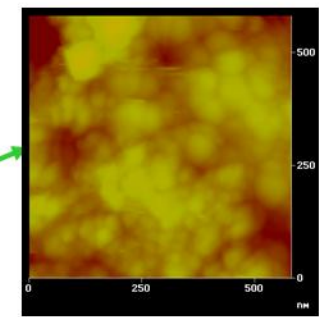
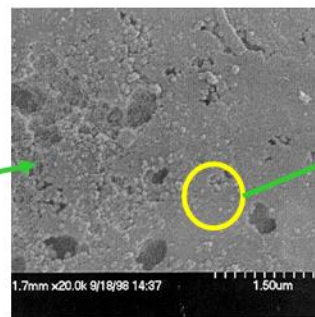
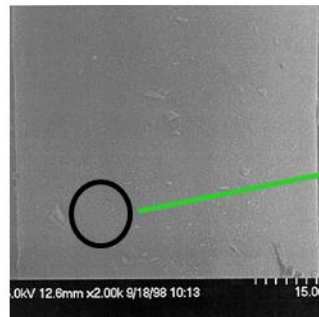

-KOH 賦活: Nanoporeサイズ制御: キャパシタ物性画期的向上

-1050°C 熱処理: 表面性質制御: DeSOx性能画期的向上

-硝酸処理: 表面性質制御: Chloro-compounds除去能向上

Air Purification Using ACF (Remote Watching System)

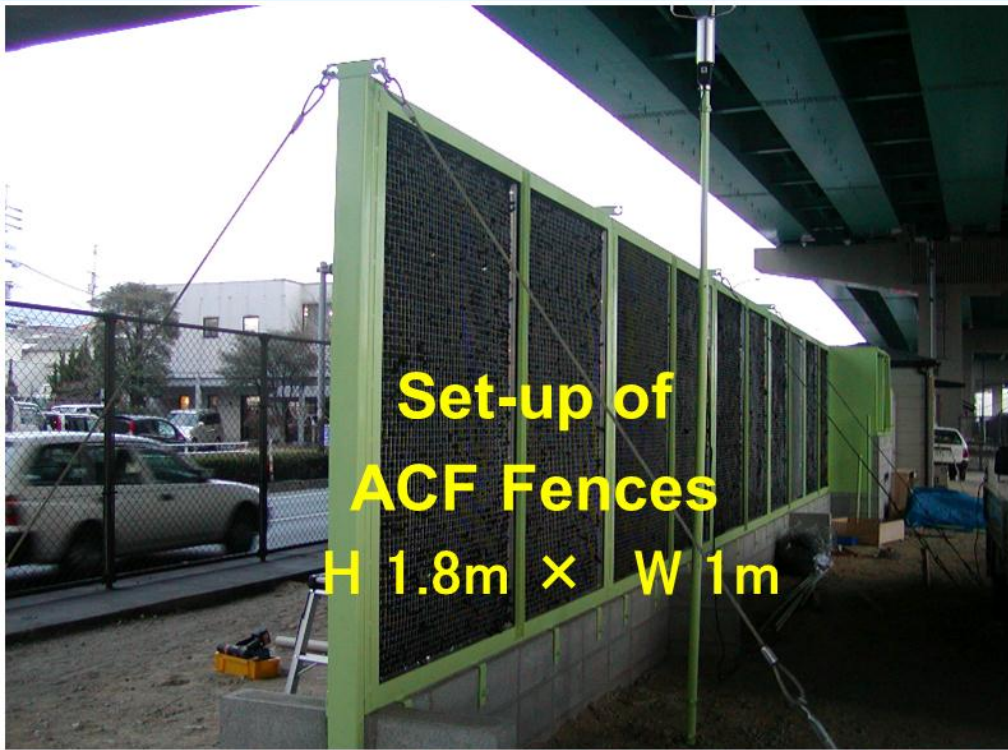

**Set-up of
ACF Fences
H 1.8m × W 1m**



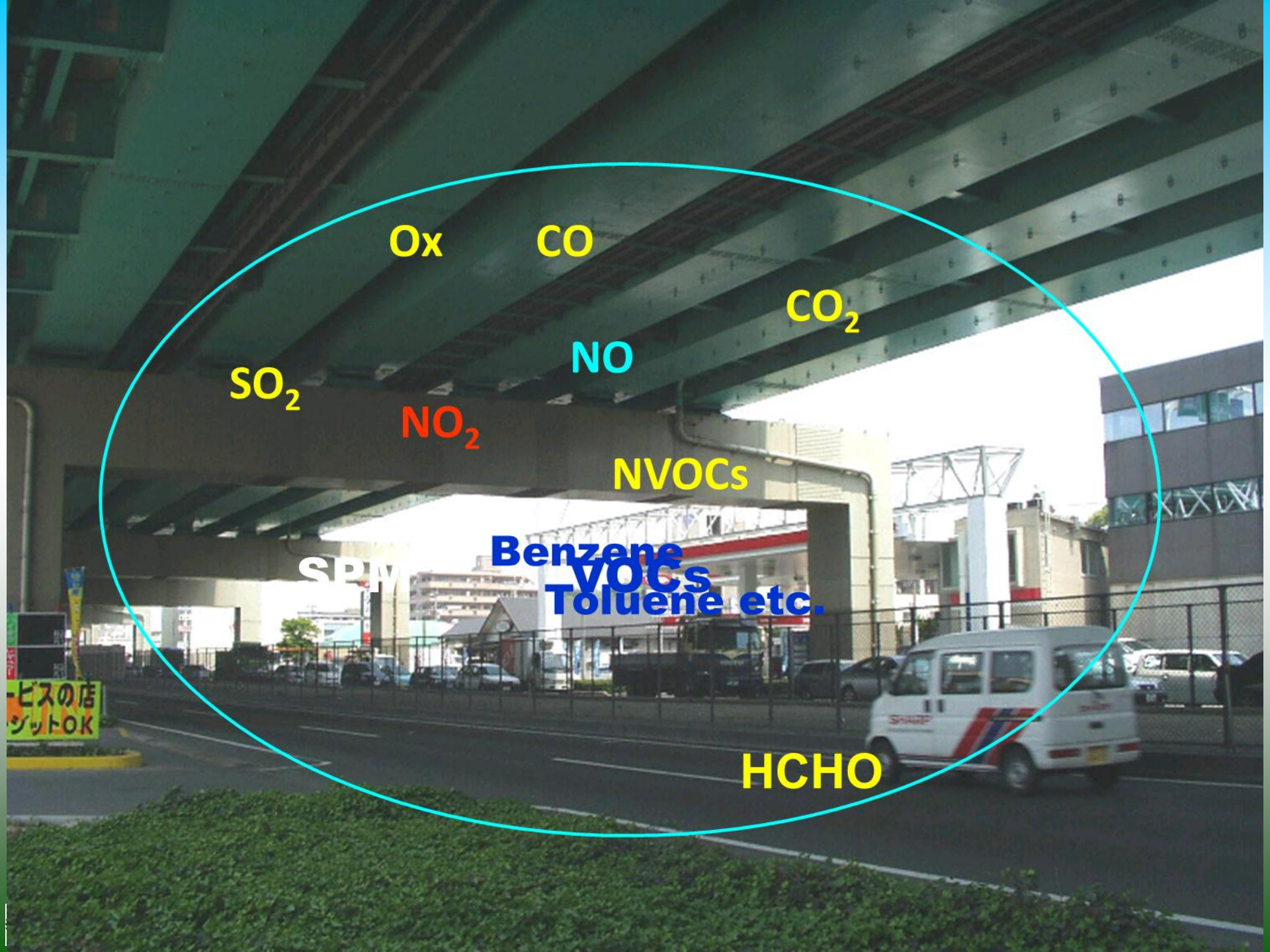

Ox

CO

CO₂

NO

SO₂

NO₂

NVOCs

Benzene

VOCs
Toluene etc.

SPN

HCHO

ビスの店
ジットOK

The VOC's concentrations on the road and scavenging effect of ACF-unit.

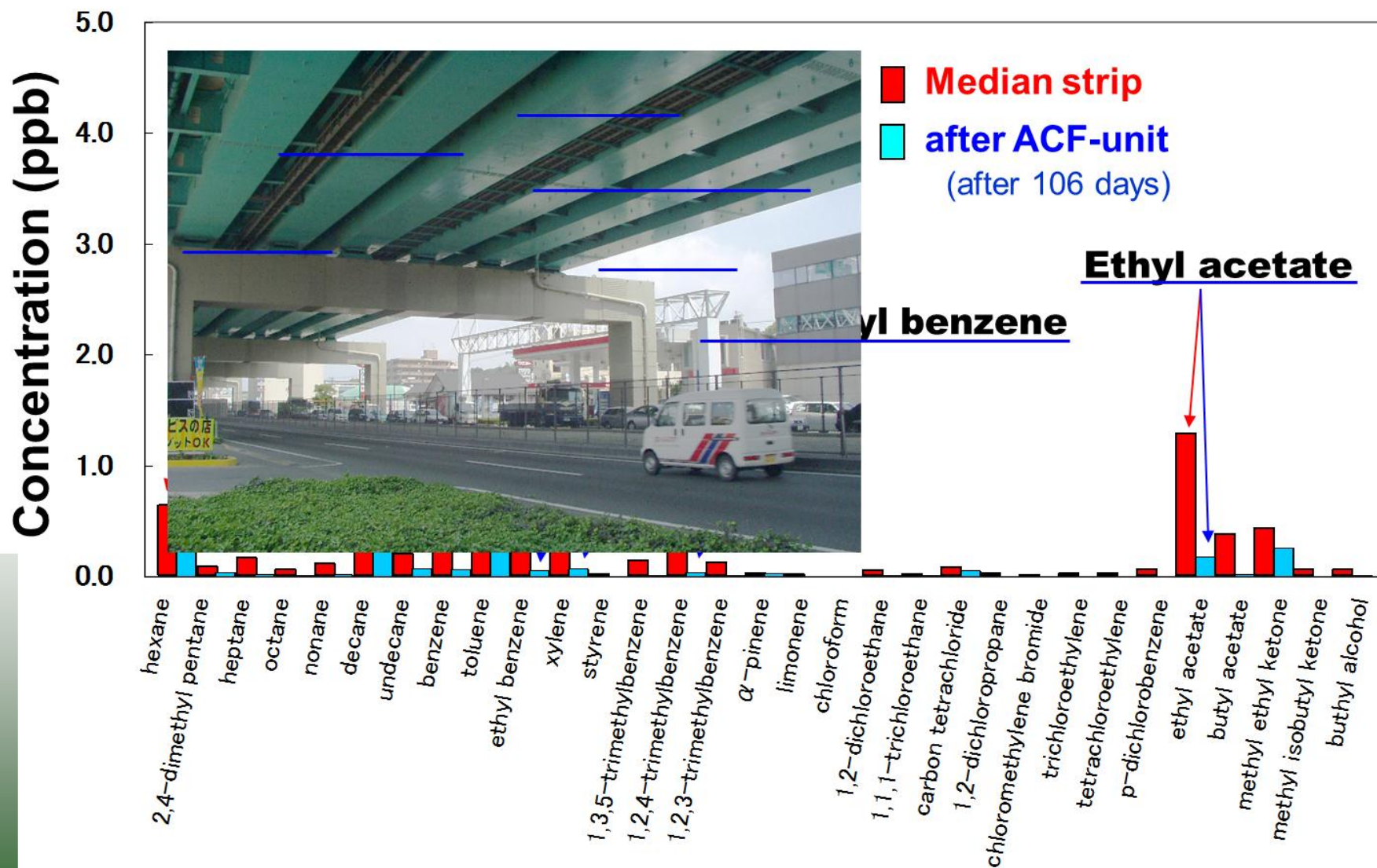

Characterization of ACF purification

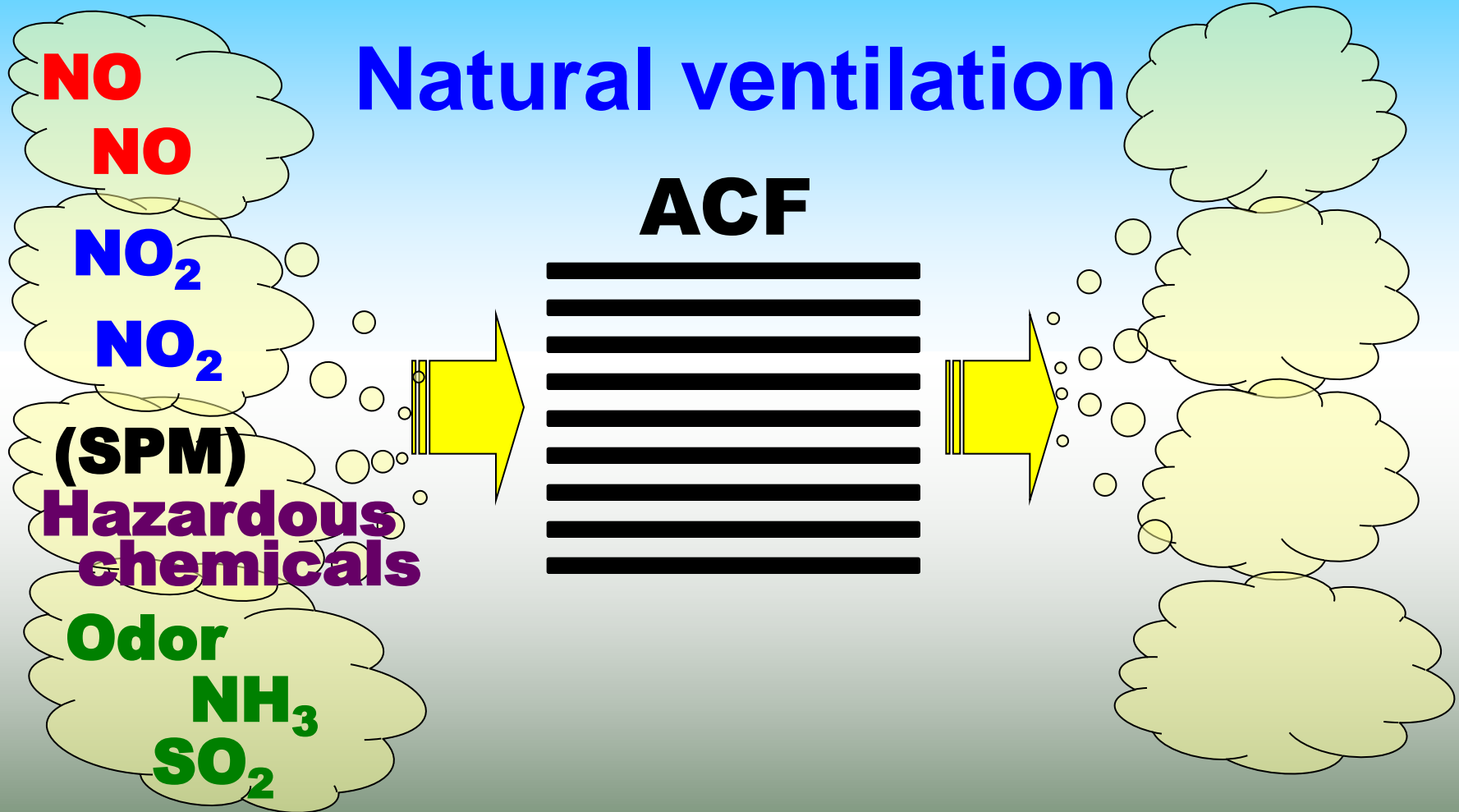

**Room temperature, ozonizer is no need,
no light irradiation, compact design**

Fig. 3 CNF-ACF複合体を利用したSO₂連続除去プロファイル

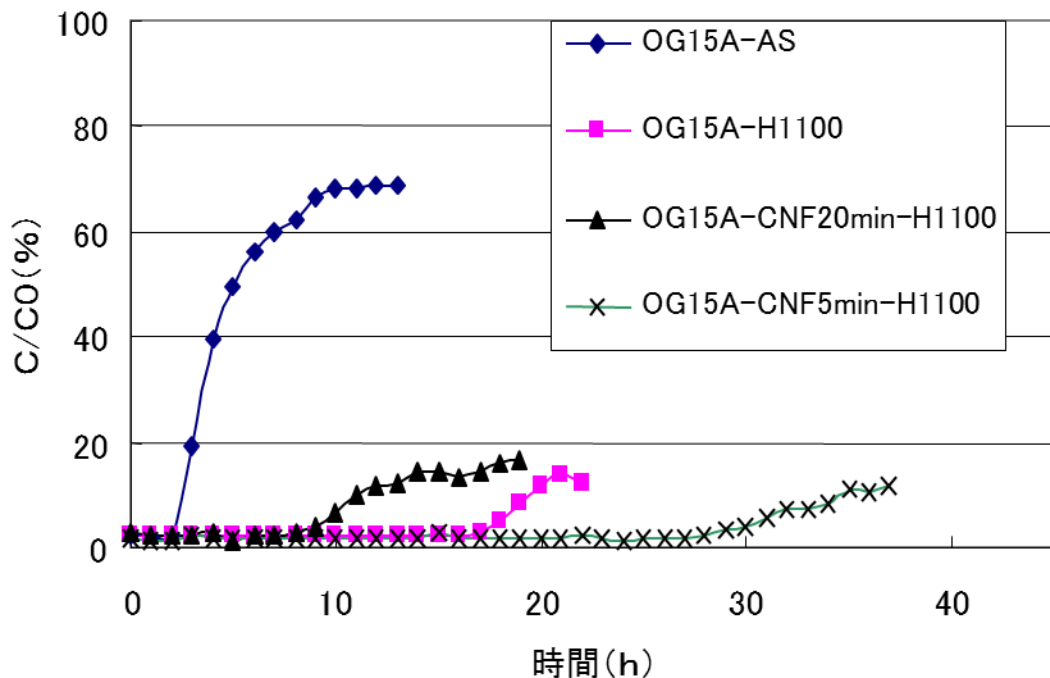

OG15A-AS: Pitch based as-prepared ACF from Osaka Gas
 OG15A-H1100: Heat treated OG15A-AS at 1100°C for 0h
 OG15A-CNF5min-H1100: Heat treated CNF-OG15A-AS composites (CNF生成時間:5分)

**OG15A-CNF5min-H1100を利用し、OG15A-H1100よりさらに高い排煙脱硫性能を達成した。
 (完全脱硫:28時間以上、定常脱硫率:85%)**

OG15A-H1100を利用した硫酸回収型排煙脱硫装置は、パイロットテストを終え、2004年4月から実証Plant稼動(九大ー三菱重エー大阪ガス)



CNF-ACF 複合体 (OG15A-CNF5min-H1100) の開発によってプラント容積を1/2まで縮小可能

さらに高い脱硫率を目指している

Sun Light (Solar Cell)



Silica reduction agent

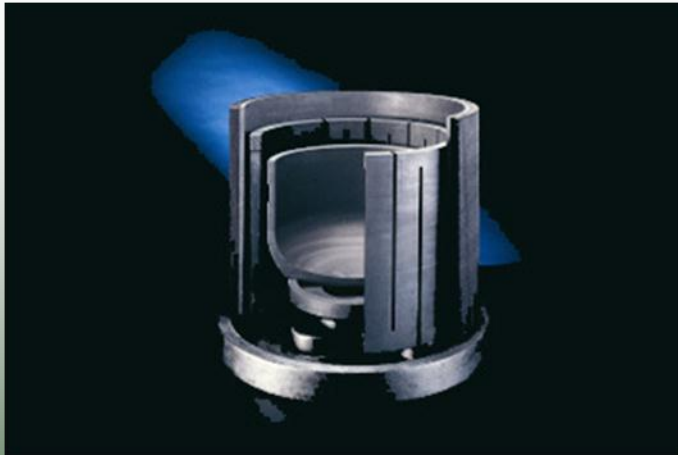

Silicone growing furnace

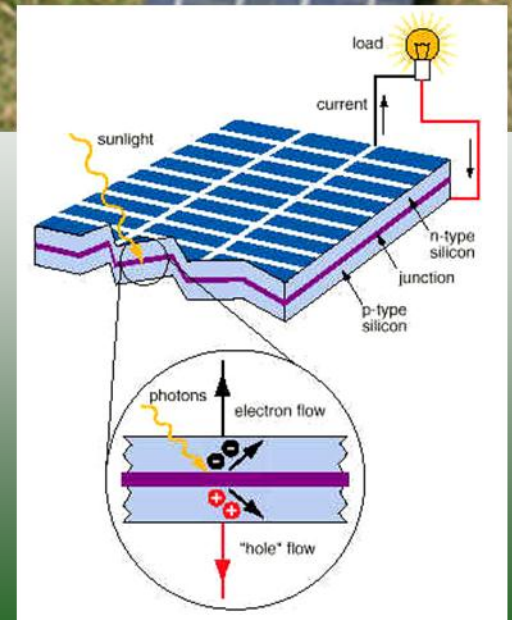
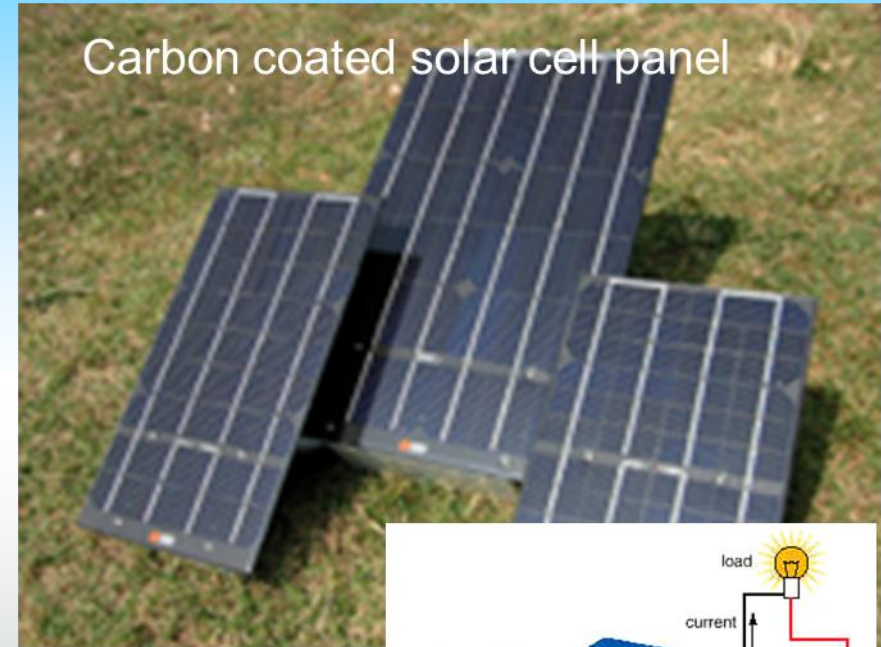

Reducing Agent Using Biomass Char and Tar



Silica reduction agent



Indonesian mangrove



Carbonization (Char)



Char

Wood tar

Coal tar or Hyper coal
With small ashes

Cokes

SiO_2 reducing agent

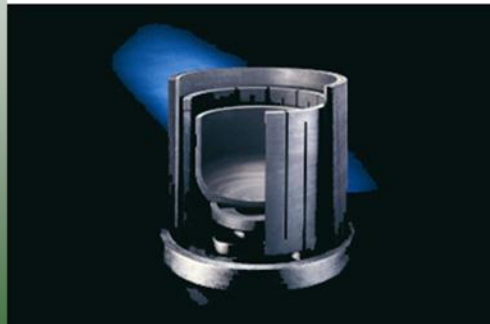
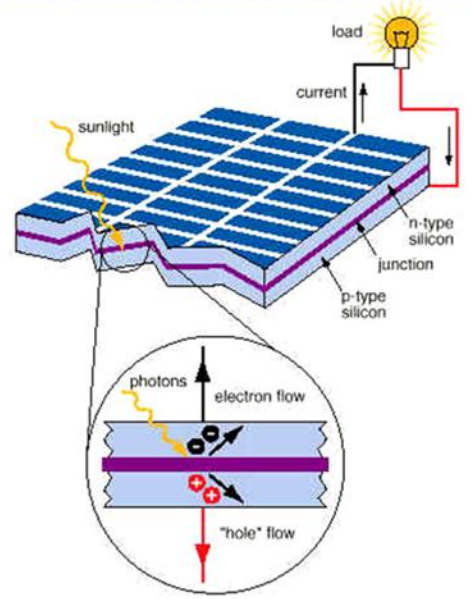

Silicone growing furnace



Atomic Reactor

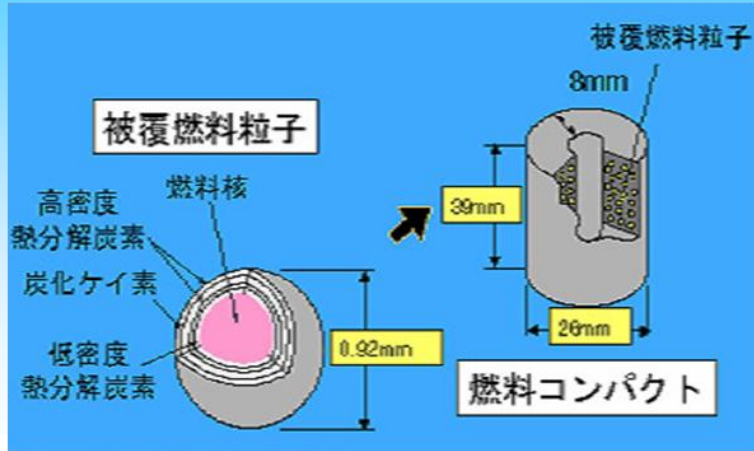

日本原子力研究開発機構 提供

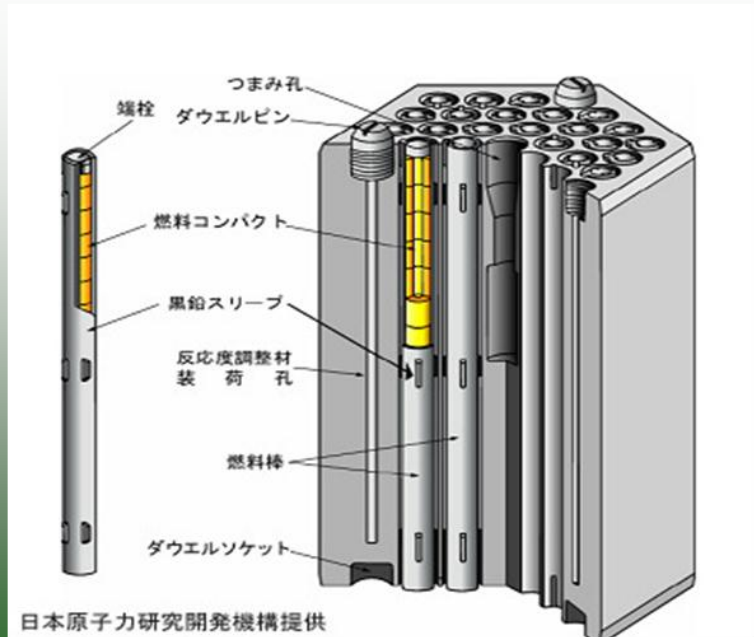
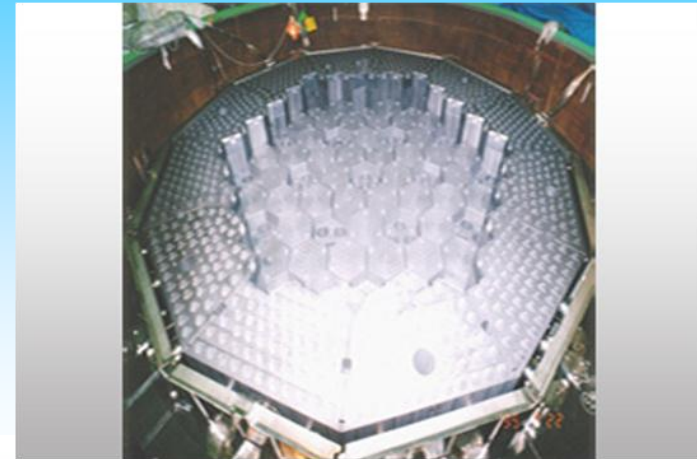

日本原子力研究開発機構提供

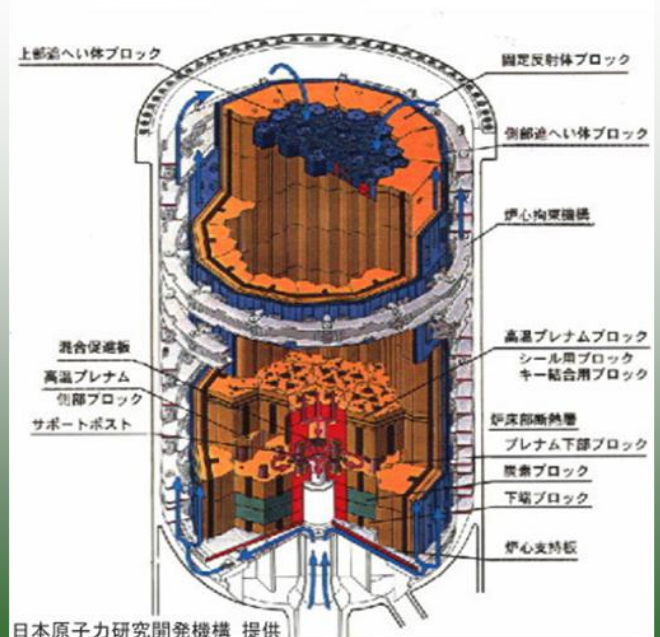

日本原子力研究開発機構 提供

IGCC & IGFC

High Temperature Gasification Reactor & Fuel Cell

The Higher Temperature the operation, The higher Efficiency.
→ Carbon structural materials



5トン/日バイオマス/廃棄物炭化ガス化実験設備

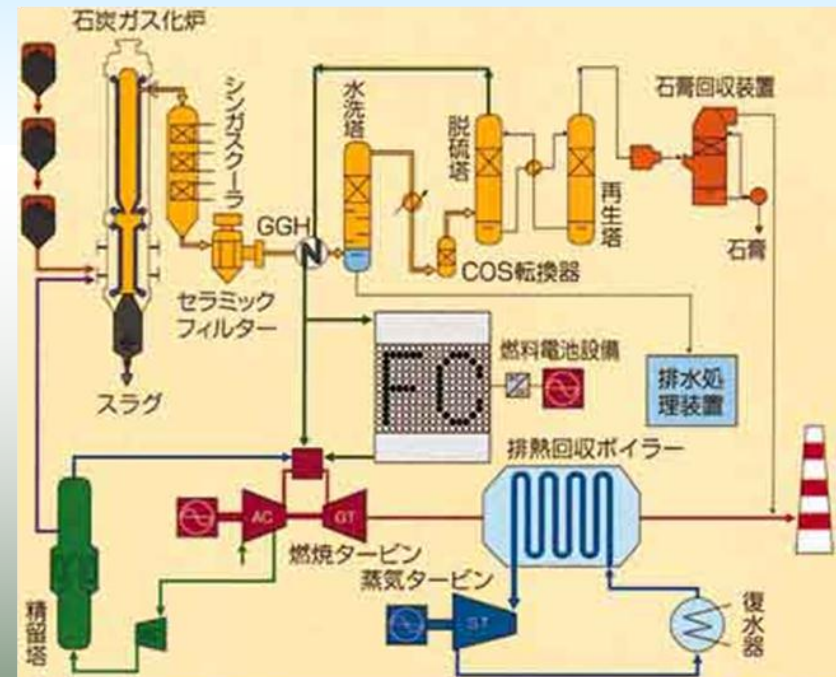

CCS - Carbon Dioxide Sequestration -

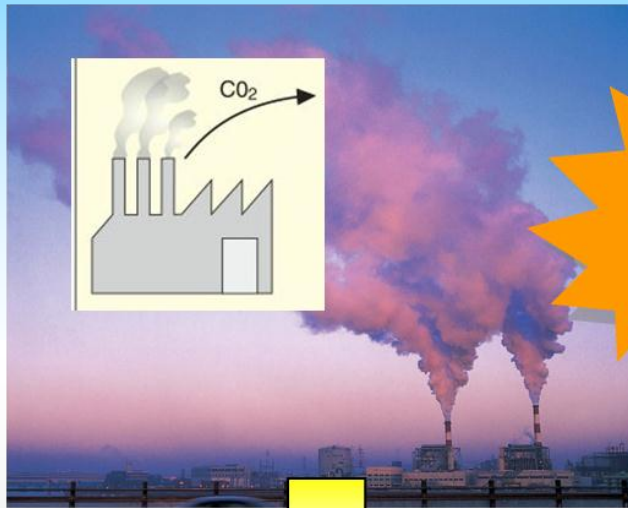

CO₂

Storage
Disposal / Re-use

Separation & Concentration
(Over 98%)

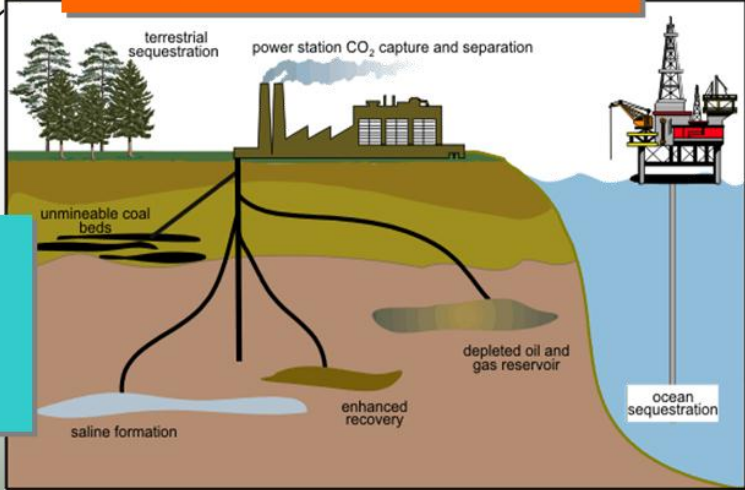

Our Lab:
Using CNF as a filler for nanofluid

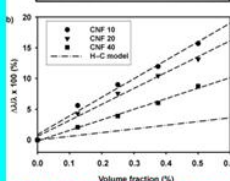
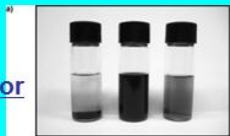
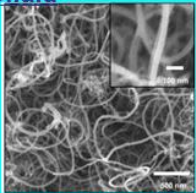

Small, Volume 3, Issue 7, Date: July 2, 2007, Pages: 1209-1213

PSA with Activated Carbon
Separation membrane with carbon ceramic filter
Absorption separation with organic amines

Graphite Electrode

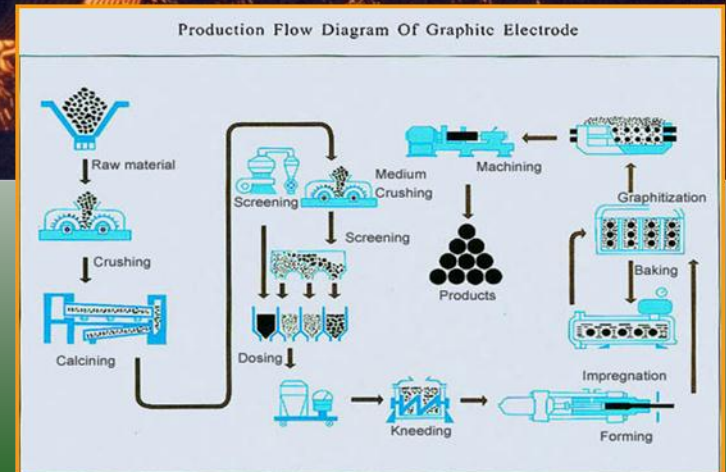
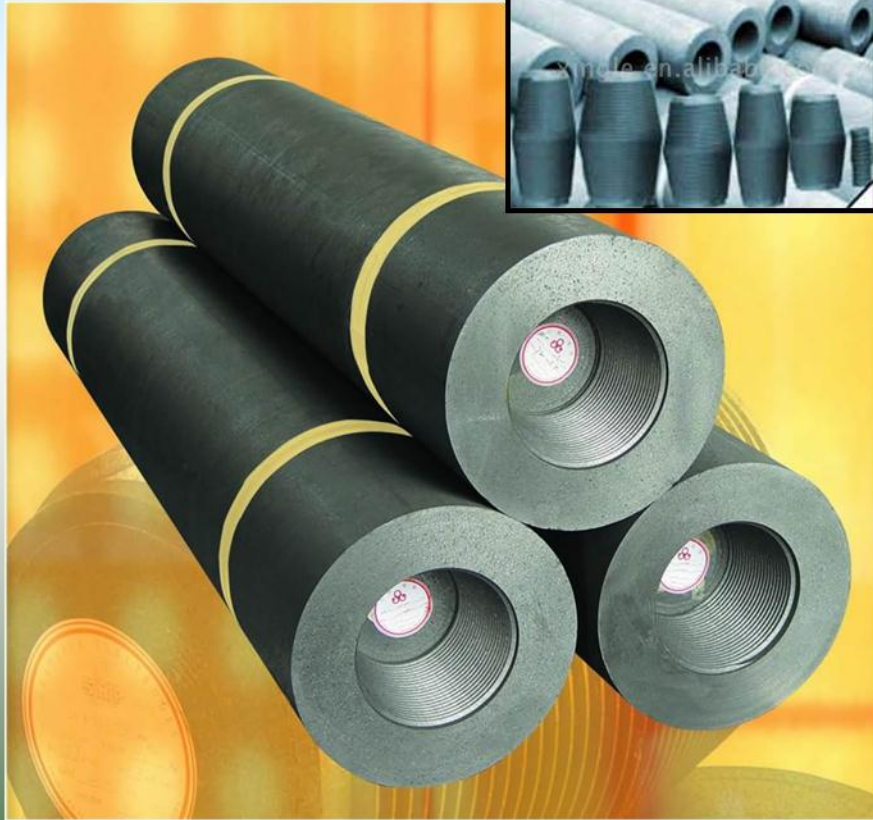

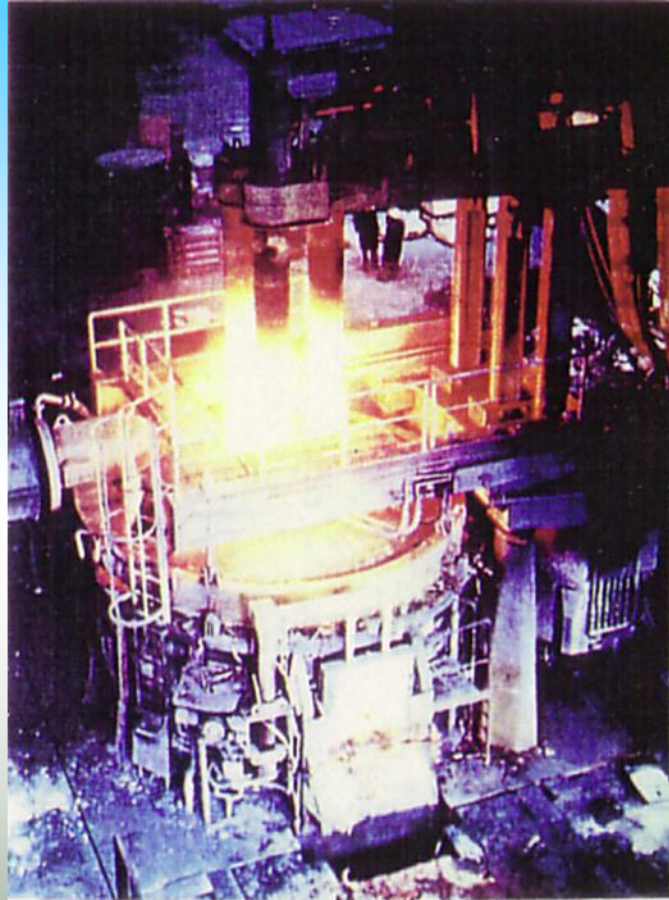

**Iron Smelting in Electric Arc Furnace.
Needle Coke Electrode.**

Advanced carbons from Biomass

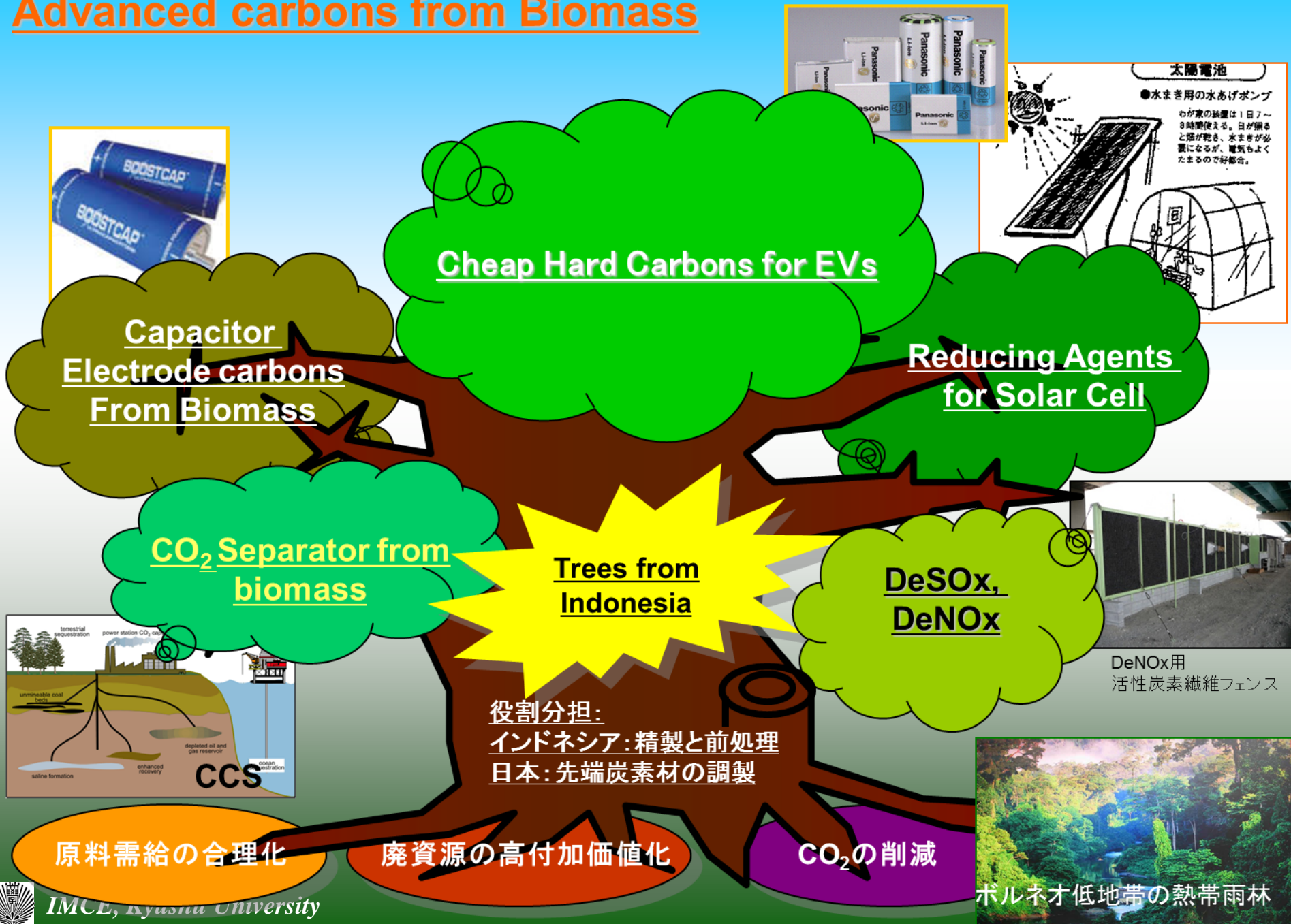

炭素材の製造

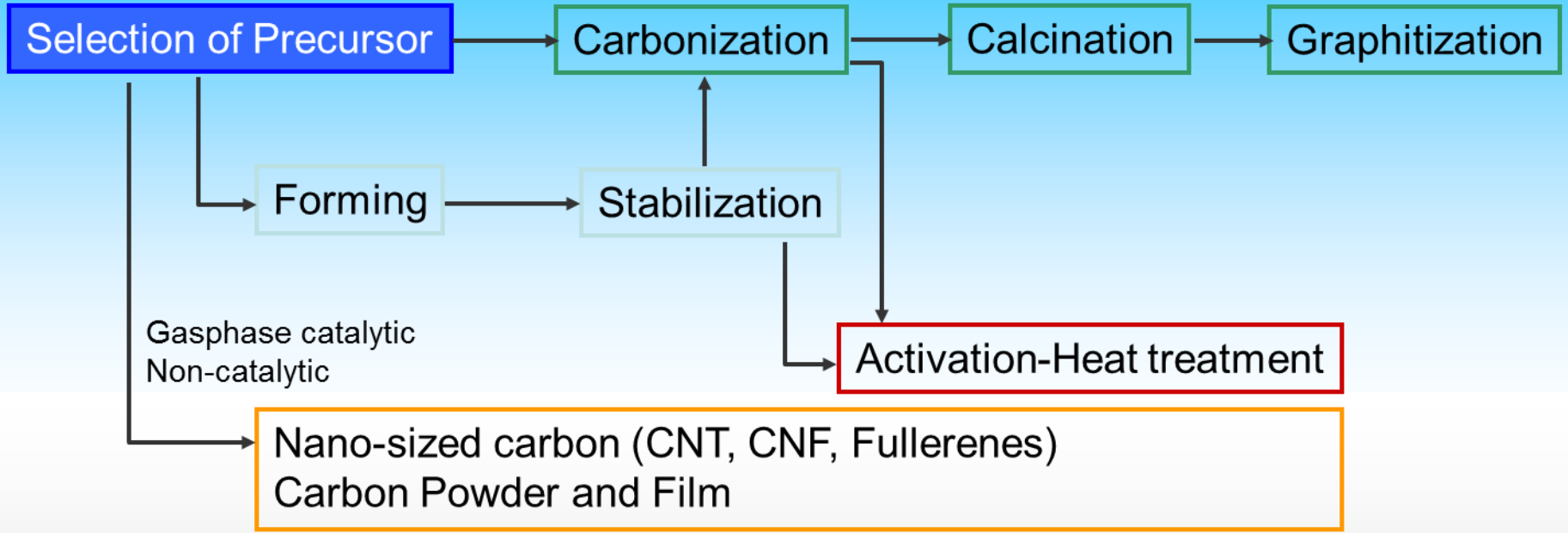

Preparation of Composite

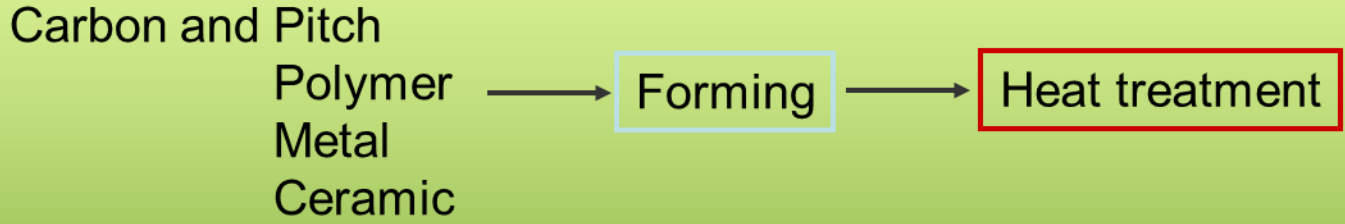

Carbon Growth on the Substrate



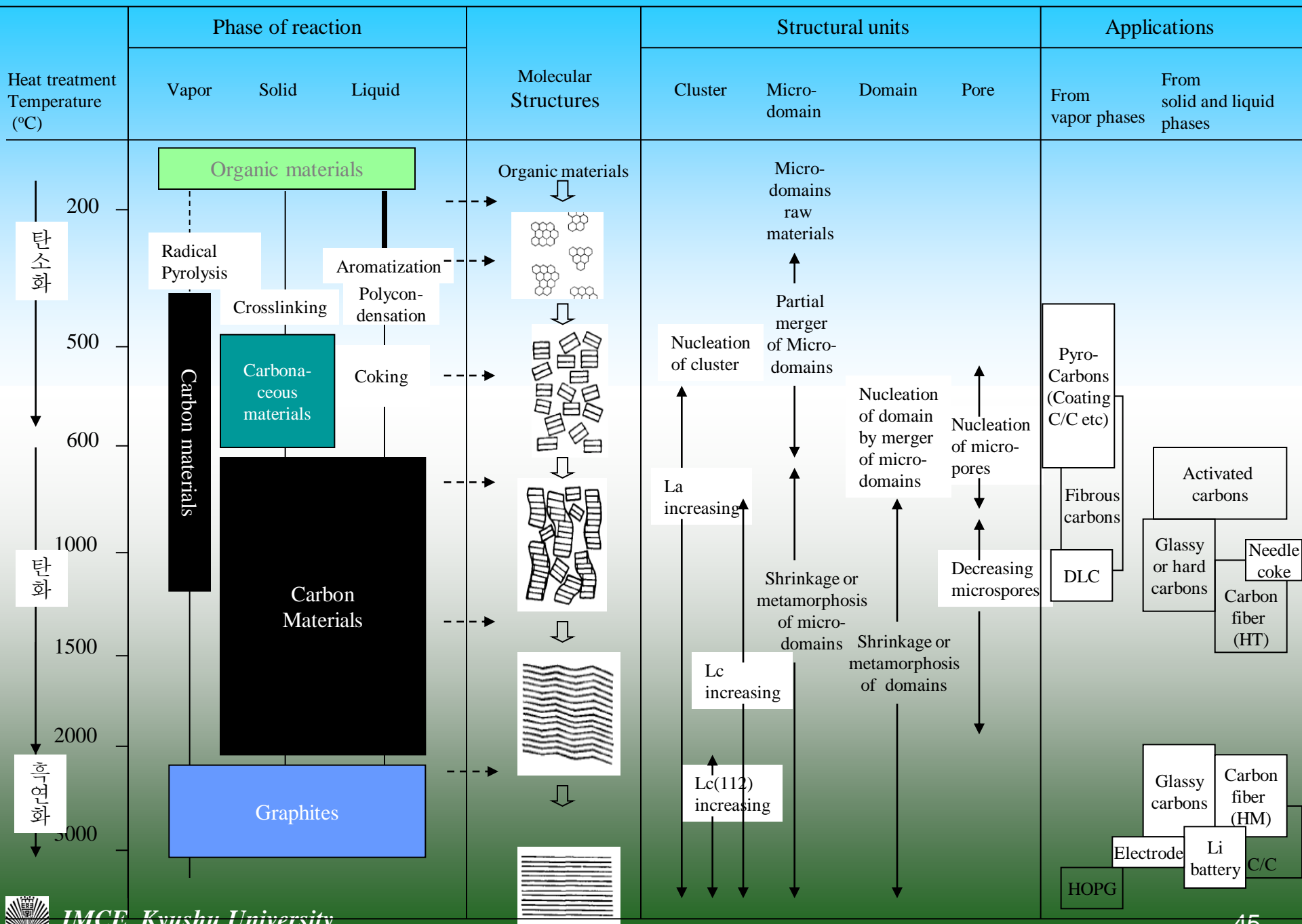

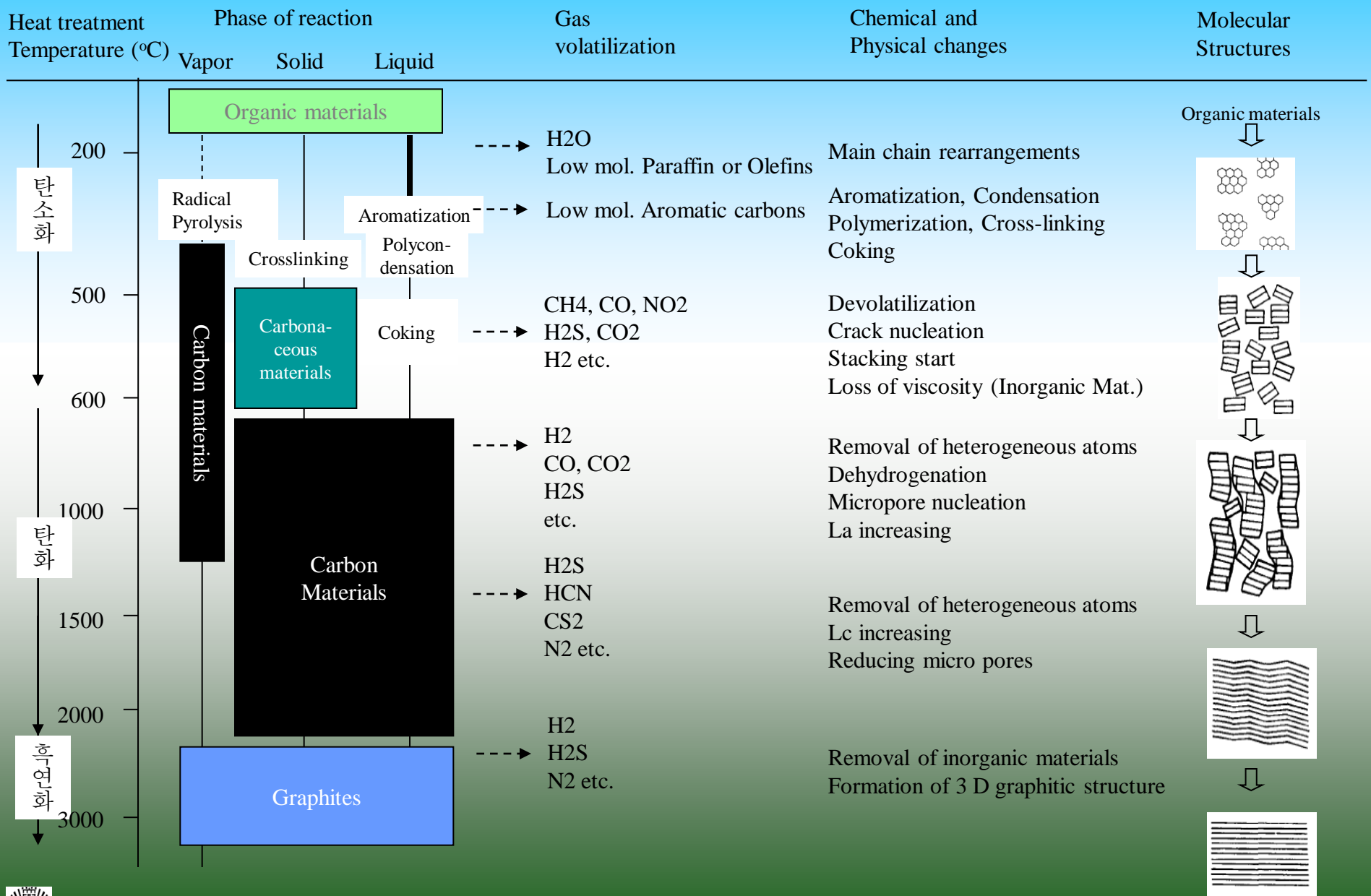

탄소화

탄화

흑연화



化石燃料から高機能性炭素材の製造と応用

Carbonaceous resources

Side products

Advanced Carbon Materials for Energy Saving, Storing, And Environmental Protections and Improvements

Effective conversion and utilization of fossil fuels and their residues

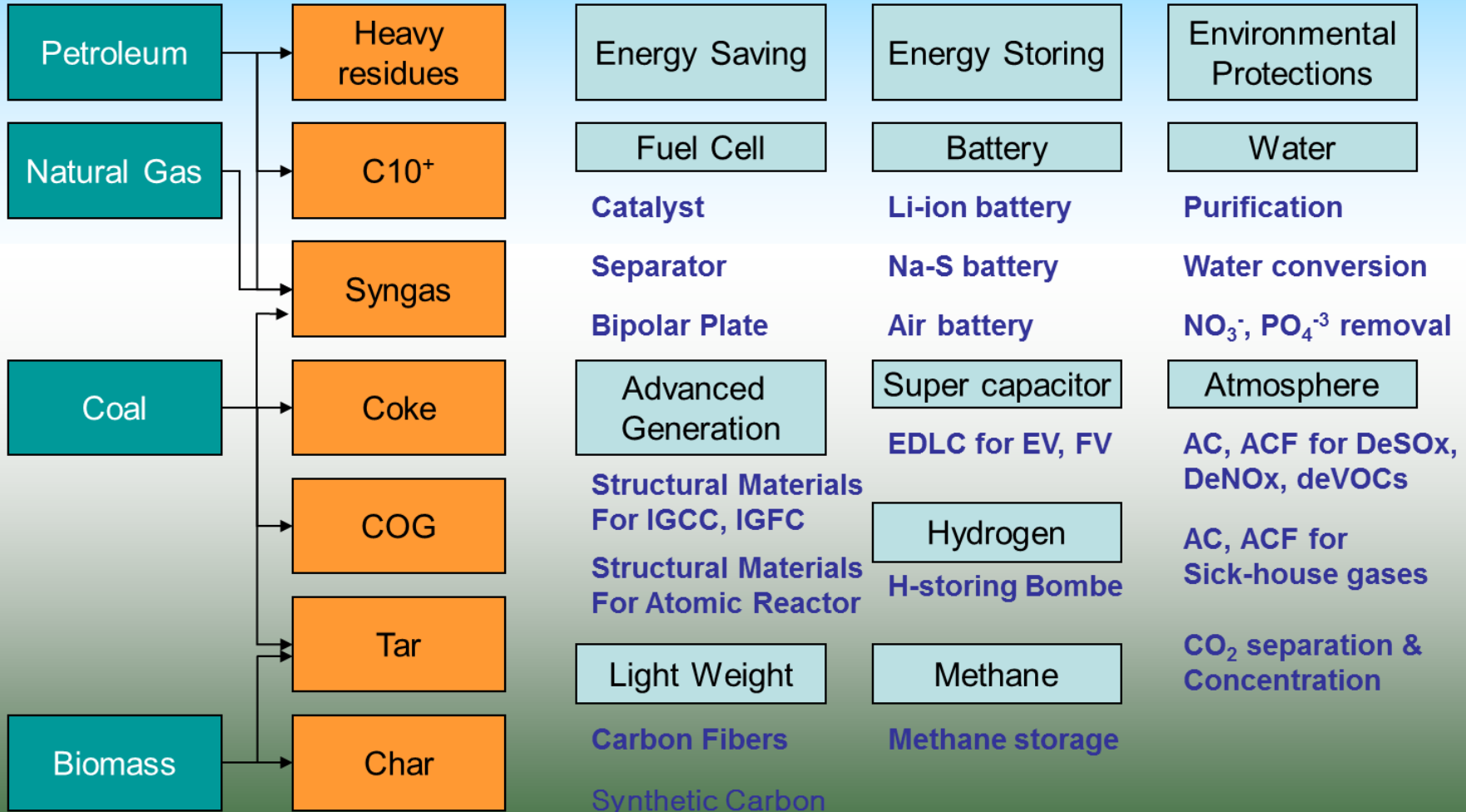

人造カーボンの構造の由来

Origin of Structural Units And Crystalline Defects

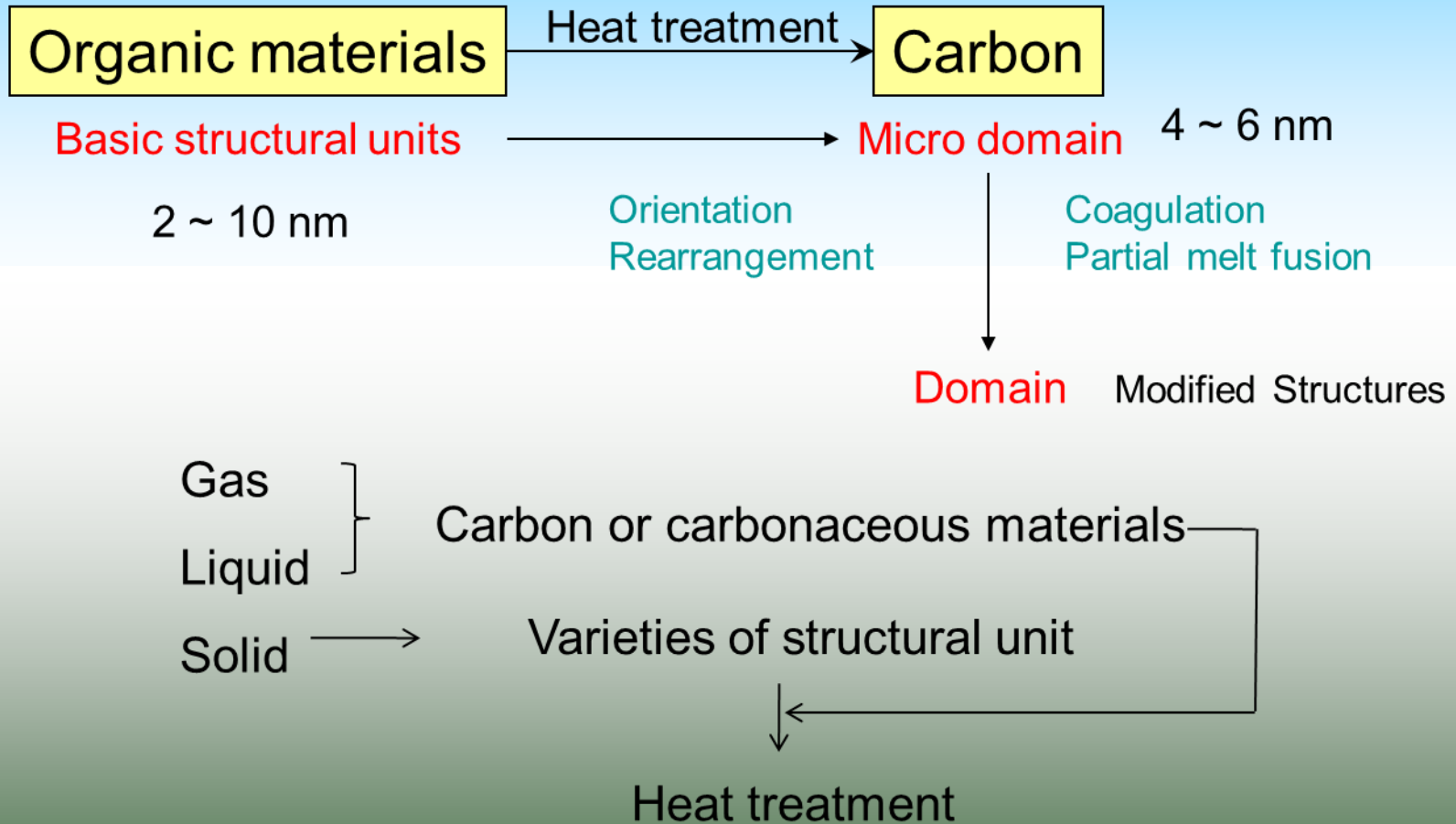

PAN系炭素繊維の構造

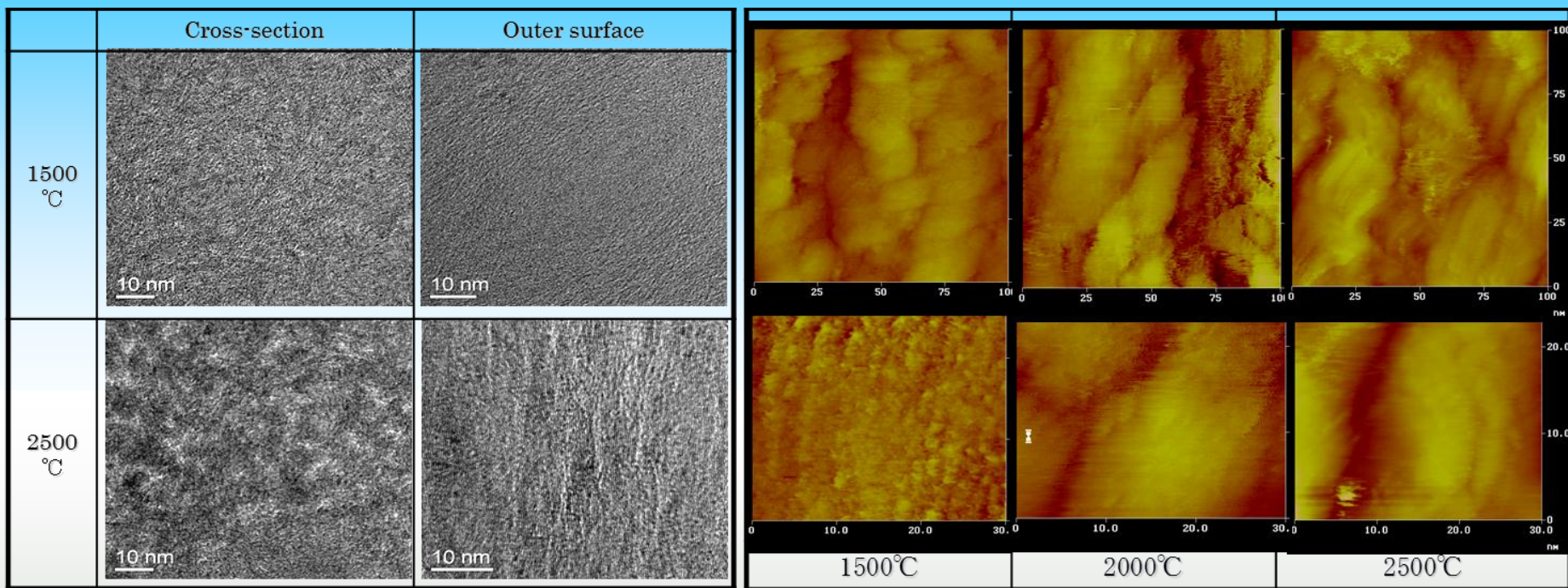
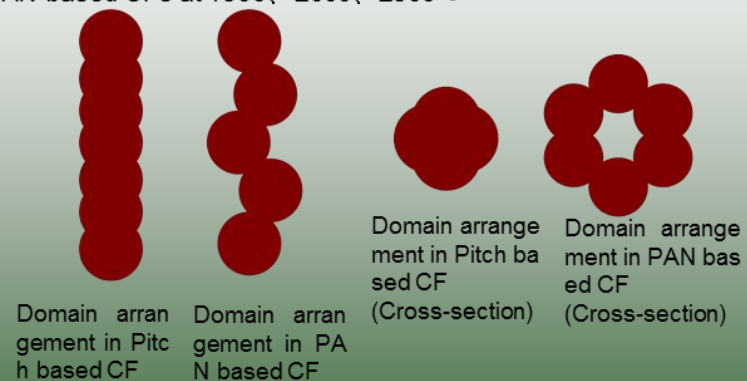
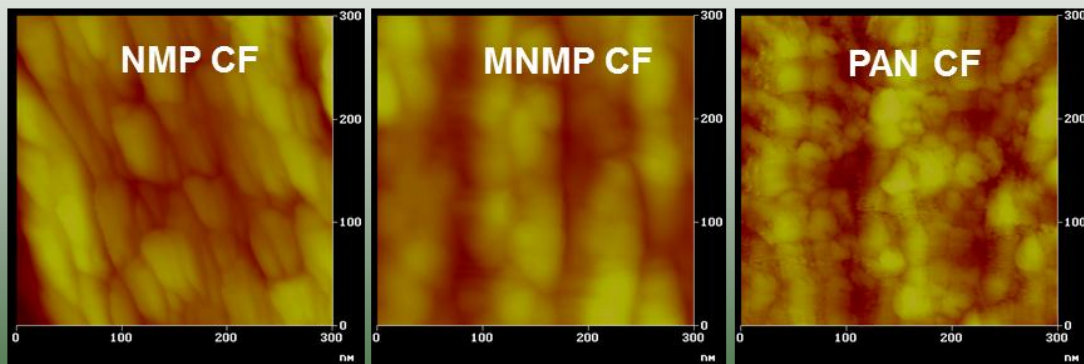

Figure SEM & STM images of heat treated PAN based CFs at 1500、2000、2500°C



“Structural comparison of mesophase and PAN based carbon fibers”
 S.H. Hong, S. H. Yoon, I. Mochida *Carbon*2006、 (2006、 7) England 49

単位構造と構造の制御

Before heat treatment

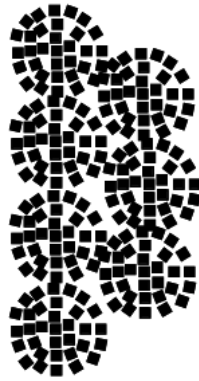

**Not or very slightly
fused microdomains**



**Partially
fused microdomains**

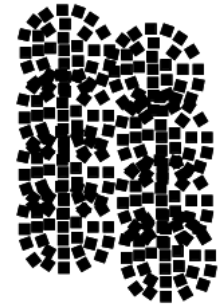

**Fully
fused microdomains**

After graphitization



Glassy Carbon

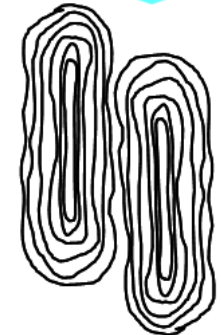

構造概念からの炭素材

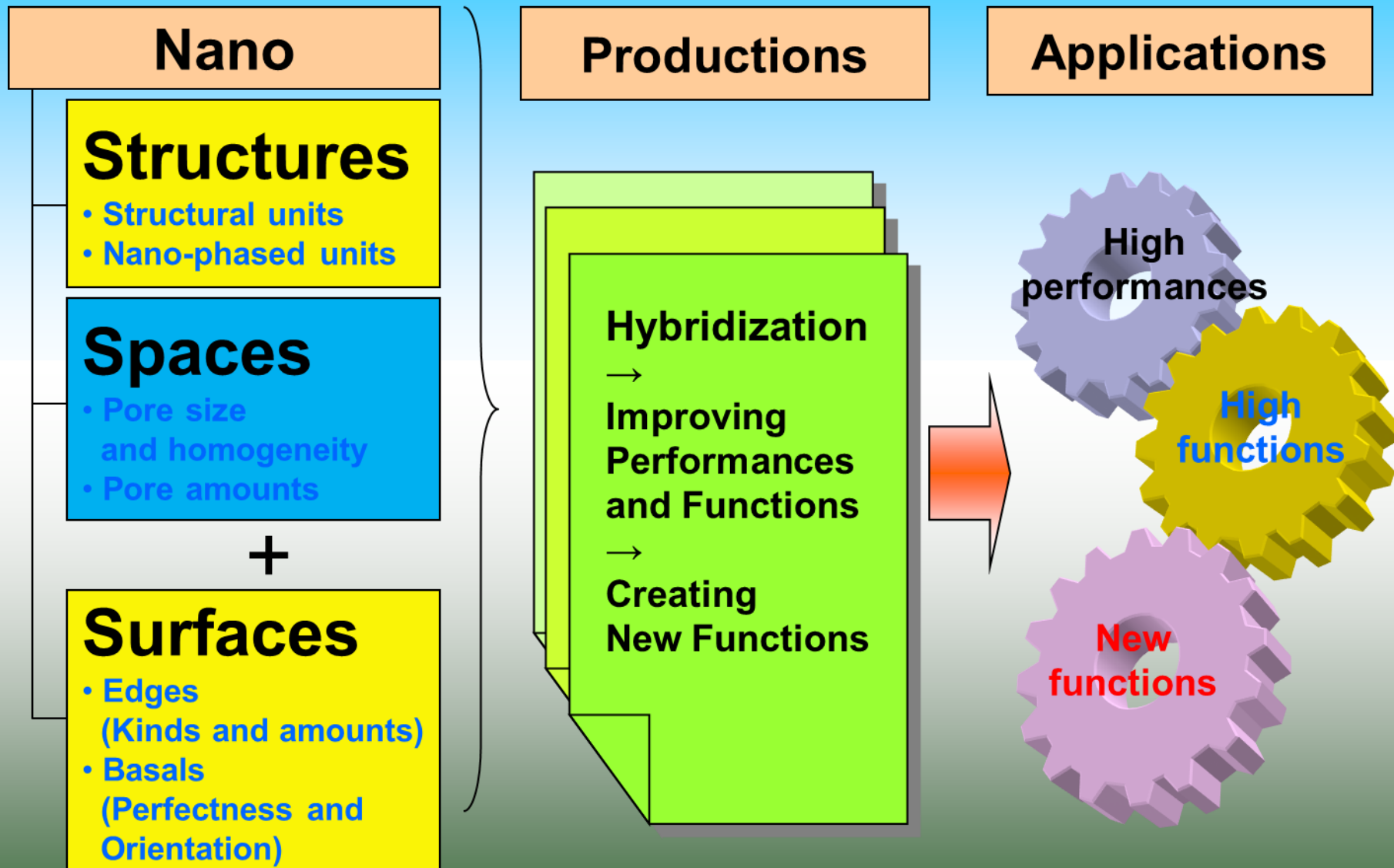

構造の制御はどこから？

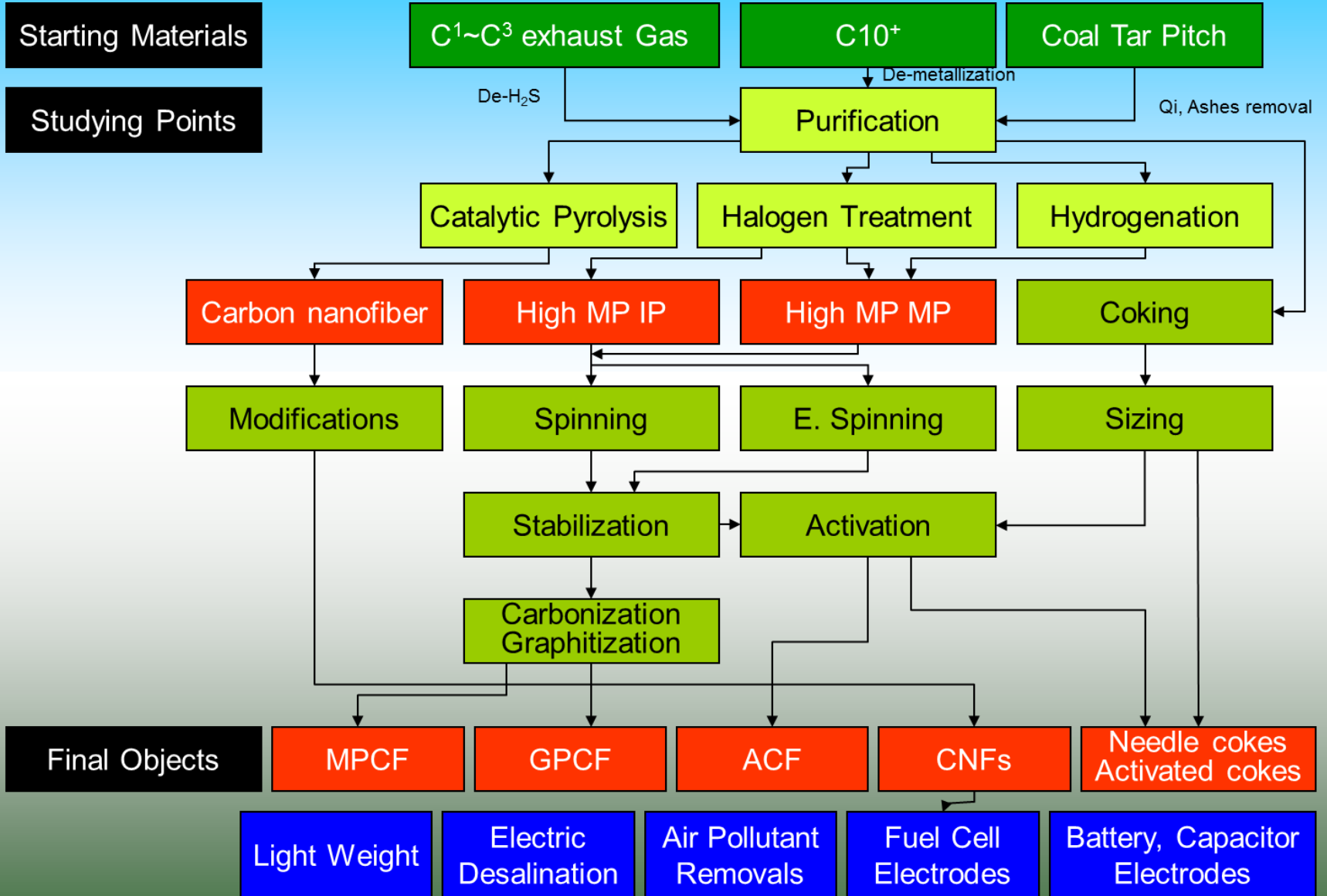

Purities of Advanced Materials

- High performance pitch based carbon fibers: less than 50 ppm
- Capacitor : less than 500 ppm
- High performance needle coke : 500 ppm
- Carbon medicines: less than 300 ppm?
- Carbon anode for LIB: less than 100 ppm
- ...

Mesophase Pitch

Kyushu University and Mitsubishi Gas Chemical Co.

Catalytic Condensation of Aromatic Compounds into Oligomers

Non-hydrogenation Condensation: Naphthalene Rings

Inheritance of Stacking Structures

Aromatic Rings

Hetero-atomic Constituents in the Reaction Substituents

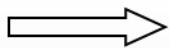
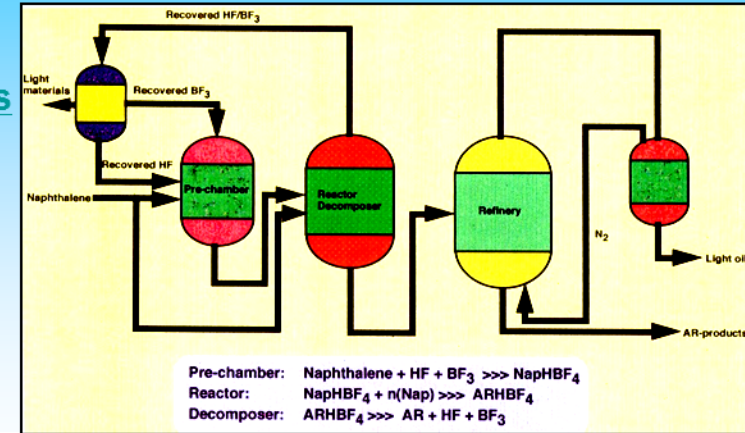

Aromatic Resin (AR)
Mesophase Pitch

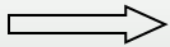

Large Variety of
Mesogen Molecules

- Removal, Recovery,
and Repeated Use of
HF/BF₃ Catalyst

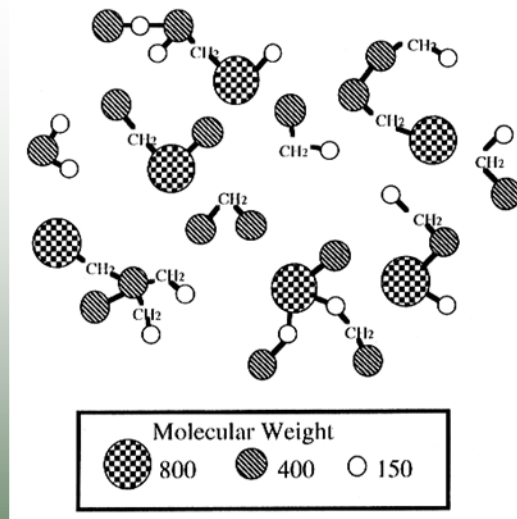

Models of mesophase constituent molecules

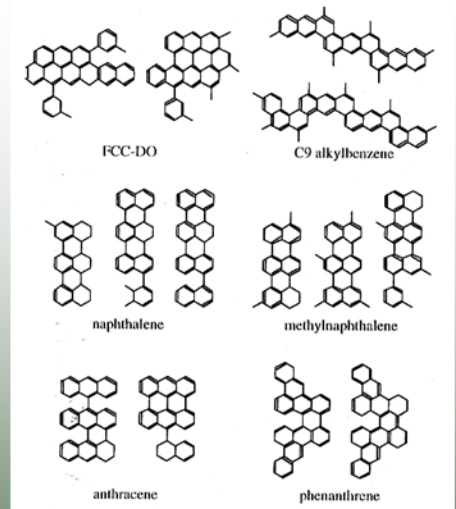

Typical mesogen units in various mesophase pitches
 (Mochida et al. Carbon 1990, 28, 311)

Relationship between the structures and mechanical properties in carbon fibers

Problem: Low Compressive Strength > Restriction of CFRP Application

Factor: Size and Distribution of Micro-domain

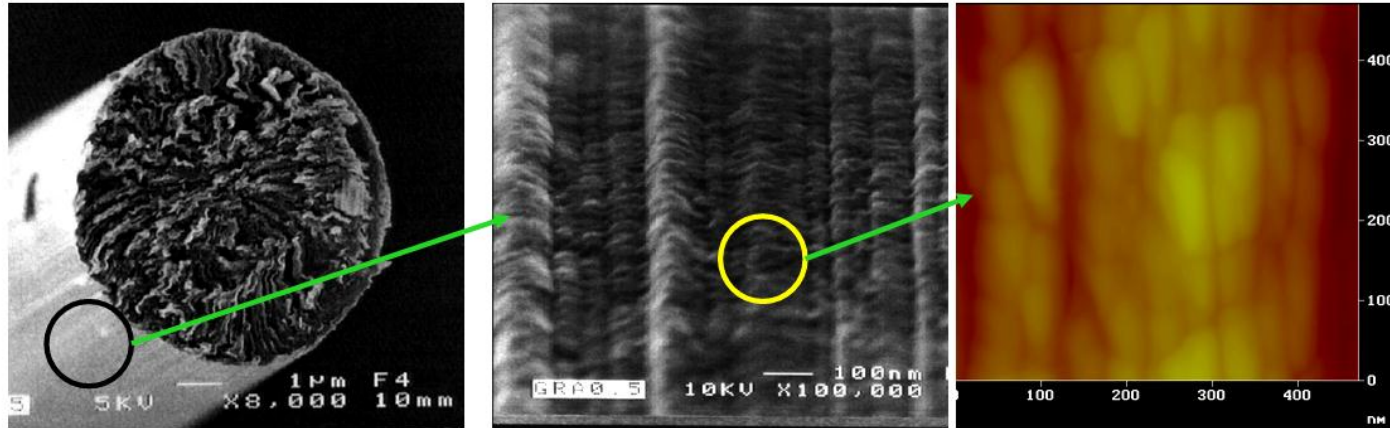

Pleat Structure > Homogeneous / Small > Increasing Compressive Strength

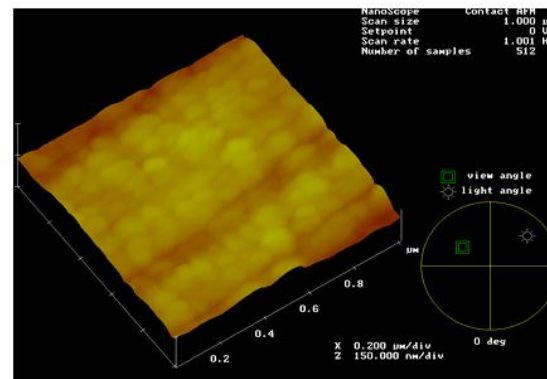
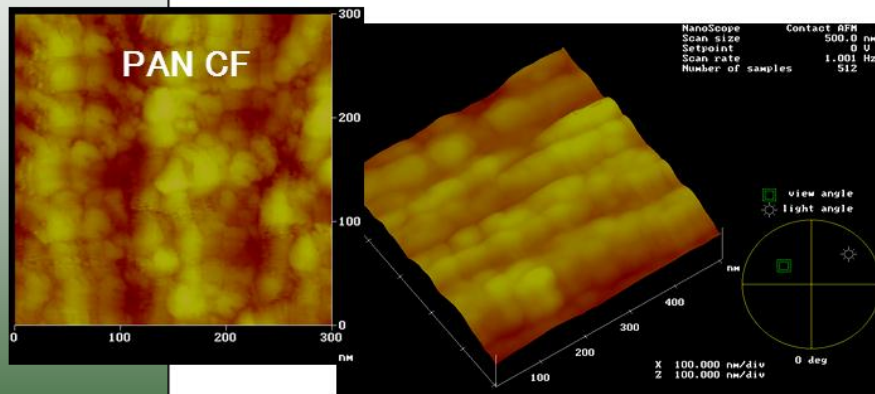

**“Pleat structure of mesophase pitch based carbon fiber”
S. H. Yoon, Y. Korai, I. Mochida *Carbon*, 32, 1182-1186 (1994)**

Mechanical Properties of Carbon Fibers

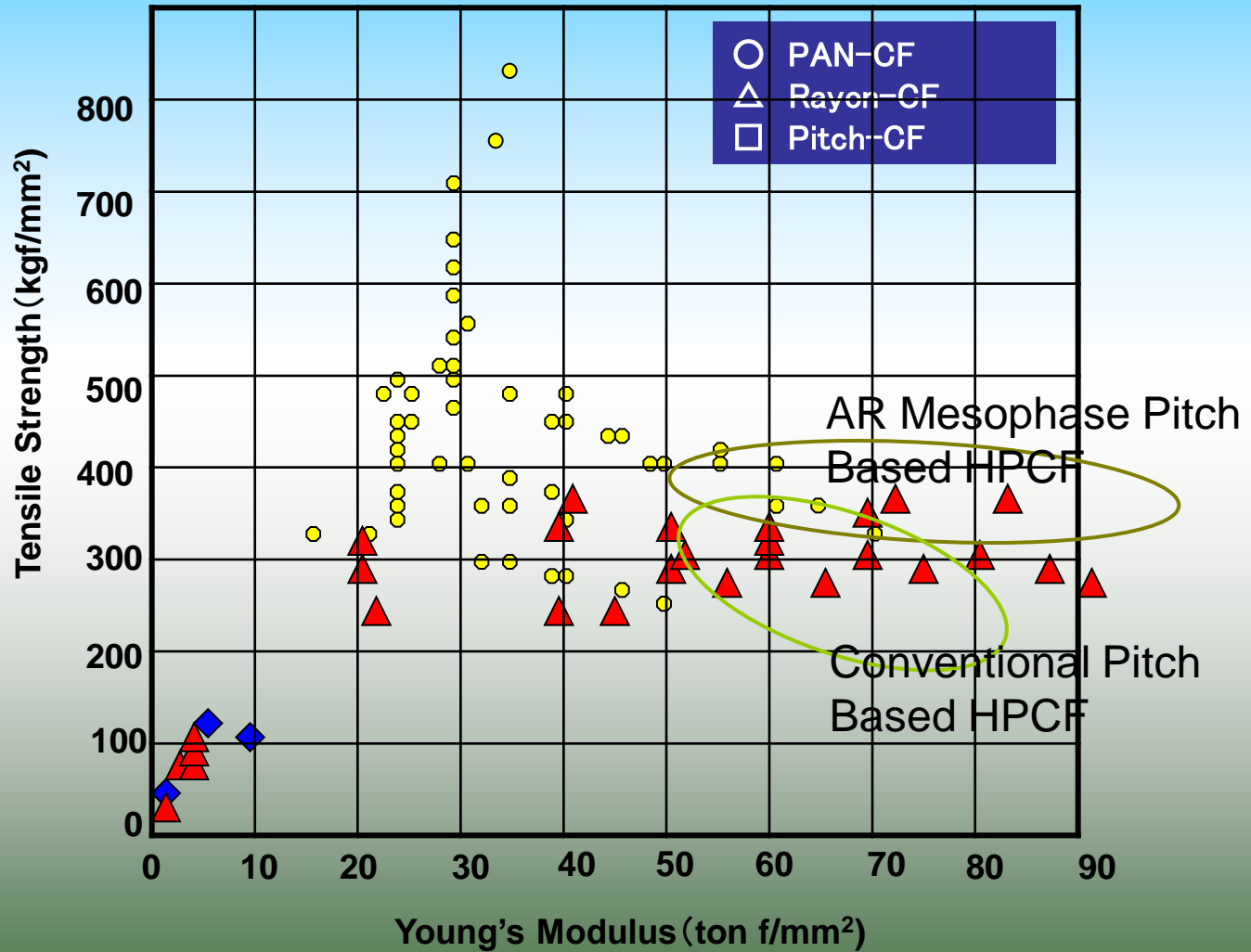

Nanoscopic Structure of PAN Based CF

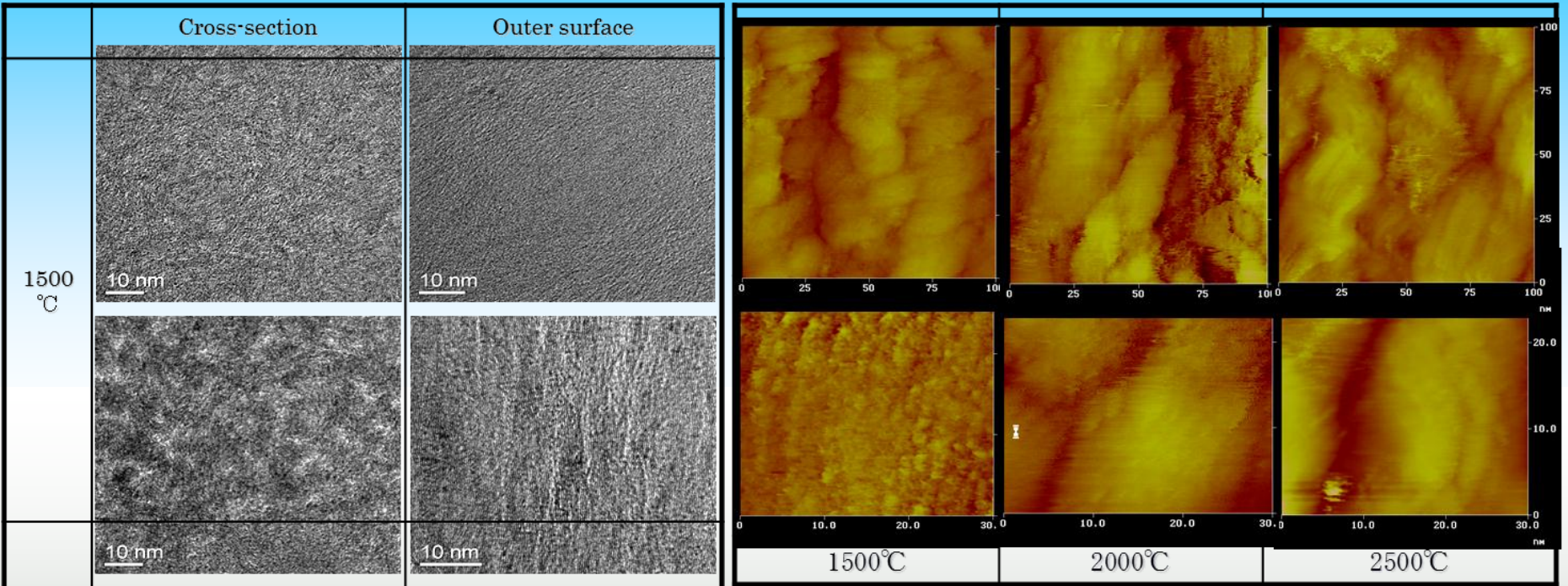
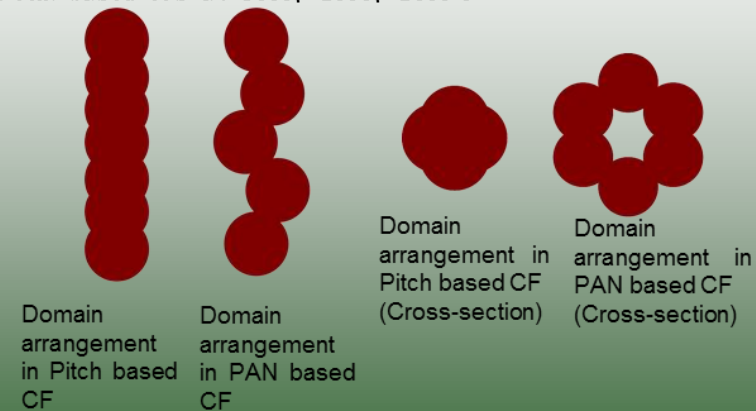
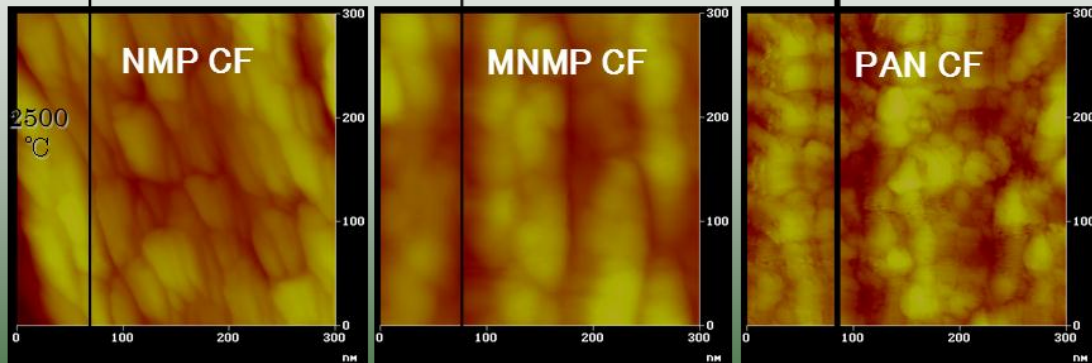

Figure SEM & STM images of heat treated PAN based CFs at 1500, 2000, 2500°C



“Structural comparison of mesophase and PAN based carbon fibers”

S.H. Hong, S. H. Yoon, I. Mochida *Carbon2006*, (2006, 7) England



Nano-carbons

Fullerene	Zero dimension Basal surface Nano-size	High price, very limited application Mass-production (Solved) (Frontier Carbon)
CNT	One dimension Basal surface Nano-size	Relatively high price (Under study) Patent problems (?) Mass-production Limited application
CNF	Various surfaces and structures Nano-size	Relatively low price Patent problems (Solved) Mass-production (Solved) Various applications Large diameter (Solved)
Graphene	Dimension-less Particular surfaces	Relatively low price Patent problems (Solved) Mass-production (Solved) Various applications



Selective Preparation of CNFs and Relatives

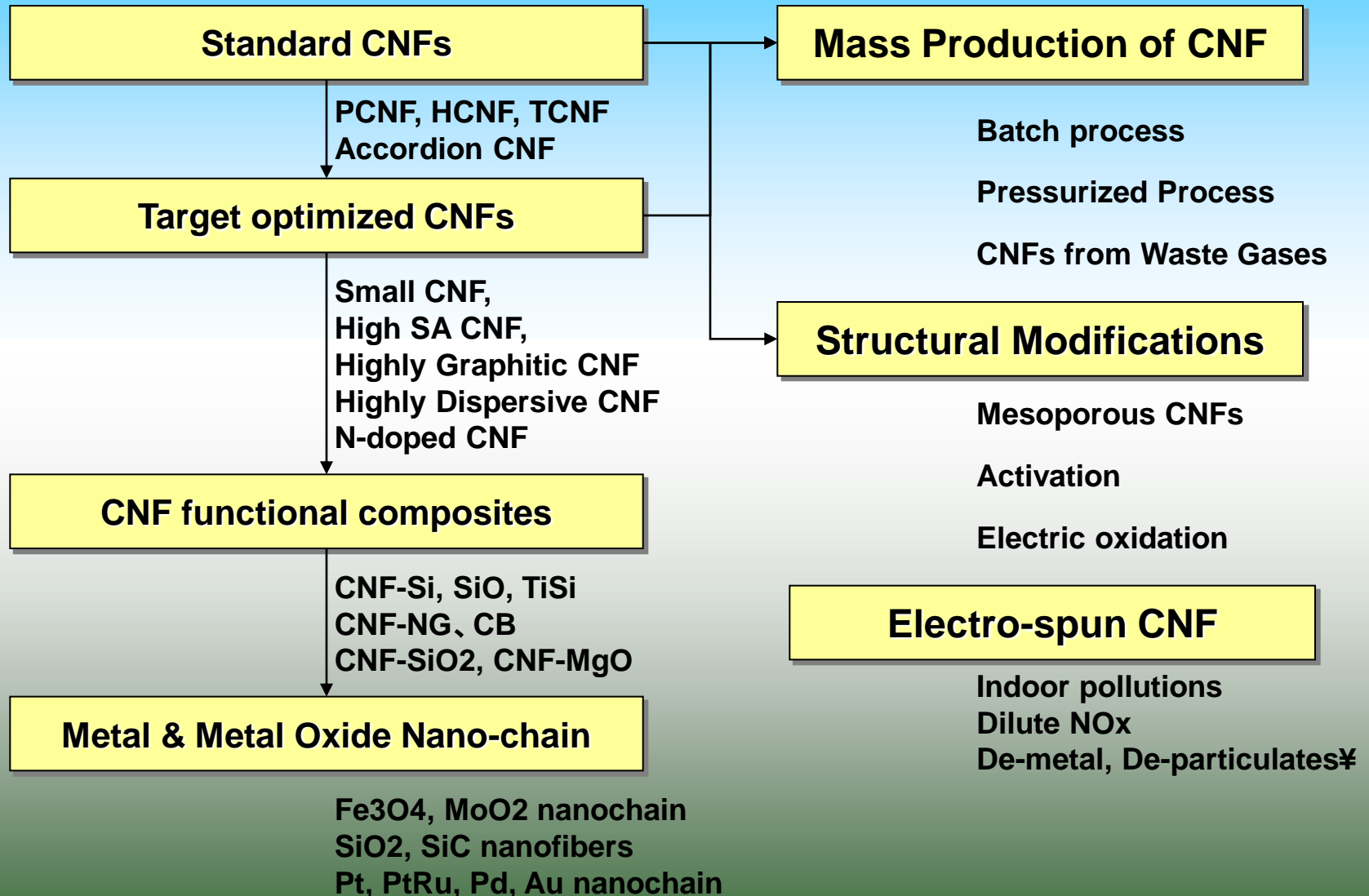

Standard CNFs

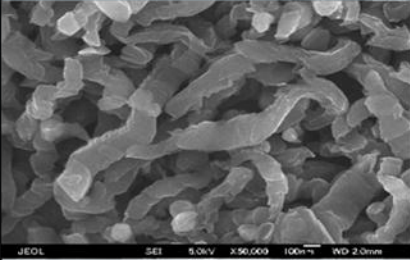
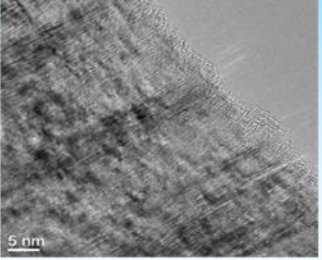
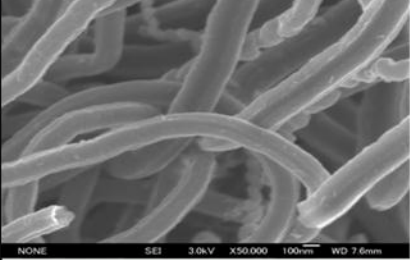
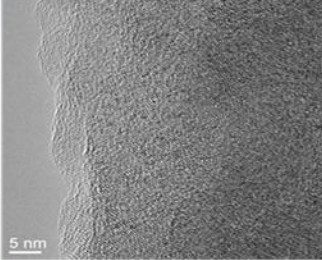
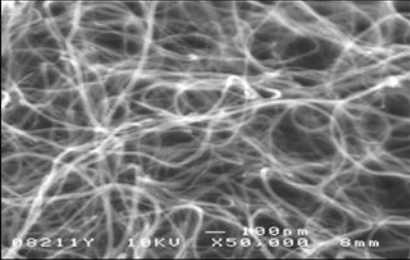
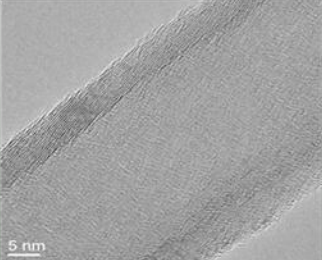
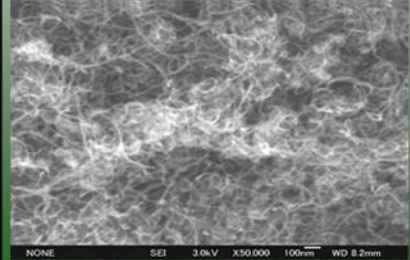
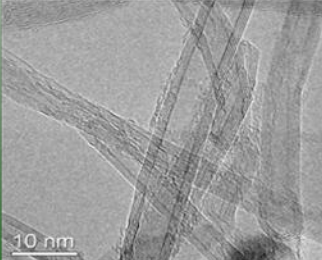
Sample #	SEM	TEM	Properties	Applications	Etc.
KNF-SPR Platelet Nano-rod			Platelet high graphit. deg. 80 ~ 400 nm, SA 90 m ² /g d ₀₀₂ 3.36Å, Lc(002) 30 nm	電池材料, 触媒担体, 触媒担体 例) 高活性水素化触媒Ru/PCNF	70 g/日
KNF-SH Herringbone			Herringbone high surface area 70 ~ 500 nm, SA 150 m ² /g d ₀₀₂ 3.45Å, Lc(002) 3 nm	複合材料, ガス貯蔵, 吸着剤, 触媒担体, FED 例) DMFC用PtRu触媒担体	100 g/日
KNF-ST Tubular 高黒鉛化性			Tubular thin walls, open tips high graphit. deg. 20 ~ 50 nm, SA 90 m ² /g d ₀₀₂ 3.37Å, Lc(002) 13 nm	複合材料, 吸着剤, 触媒担体, 触媒	20 g/日
KNF-FM Tubular 小繊維			tubular, hollow 5~15 nm, 4 -7 walls	複合材料、触媒担体、FED	20 g/日

1. Preparation of graphene⁶⁰discs

Preparation of **uniform** graphene disc

Step-by-step cutting of graphenes of platelet carbon nanofiber (PCNF)

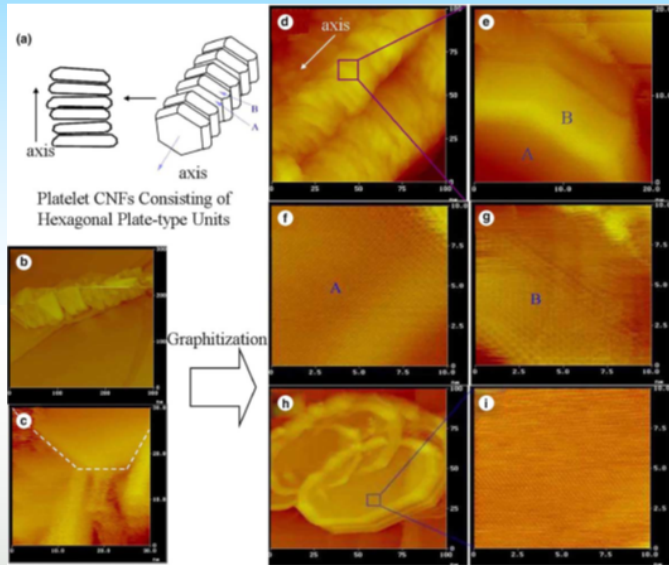

PCNF consists of nano-sized platelet structural units stacked perpendicular to fiber axis.

The plate unit has the thickness of 2–3 nm consisted of 6–10 graphene layers.

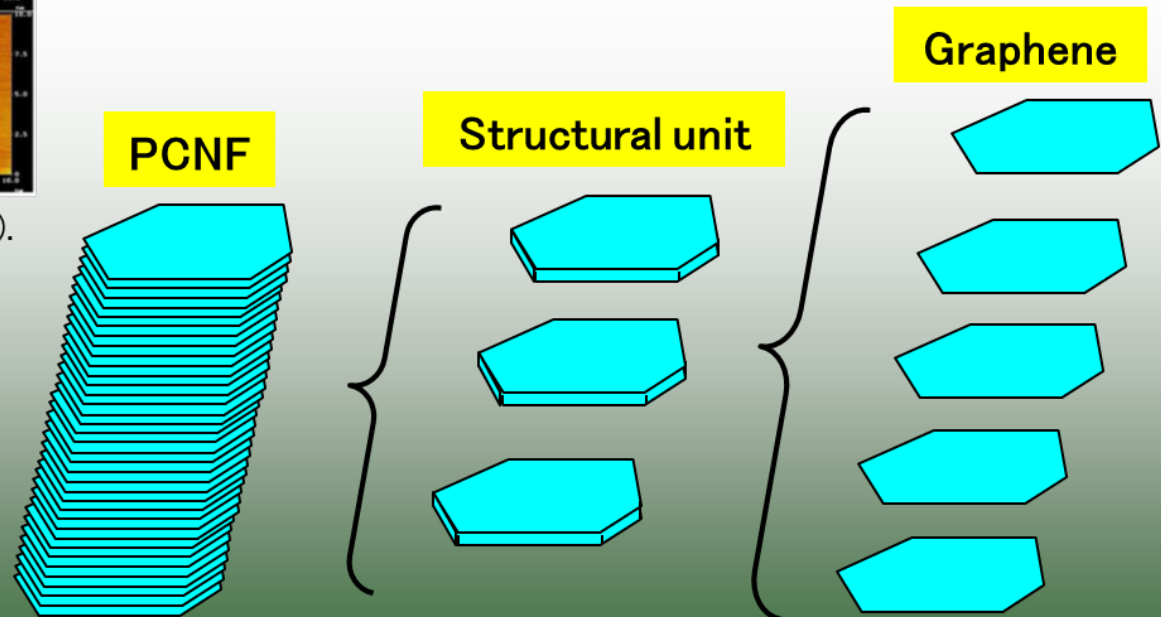

Yoon SH et al. *Carbon* **43**, 1828 (2005).

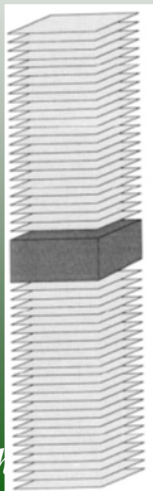

Cutting to structural unit, and then graphene

1. Preparation of graphene⁶discs

Chemical reduction of GPCNF oxide

Hydrothermal reduction using NaBH_4 at 130°C for 5 h

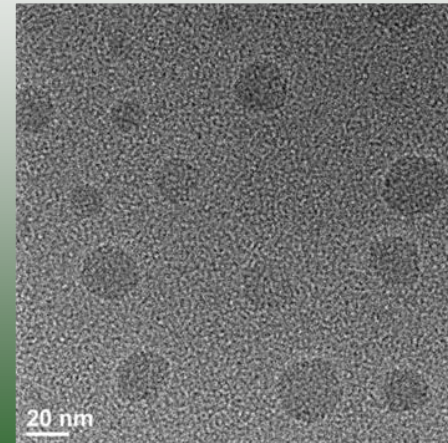
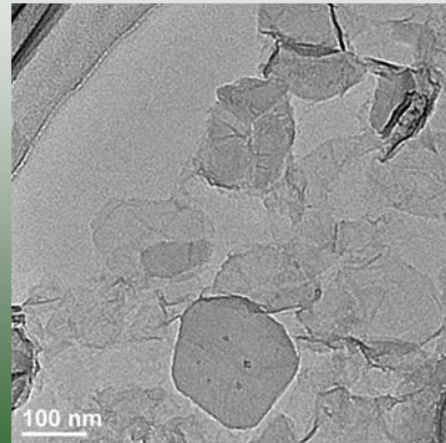
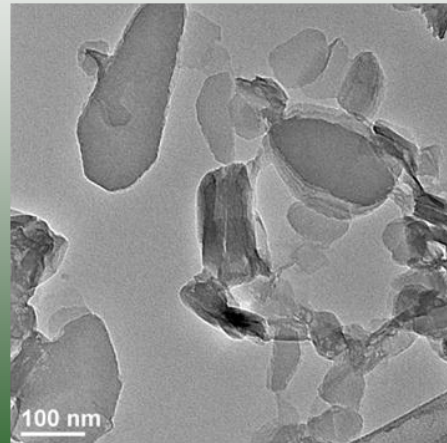
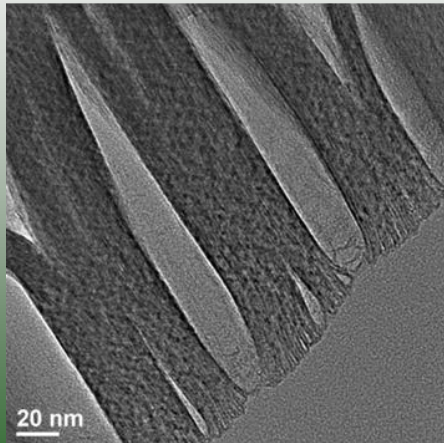
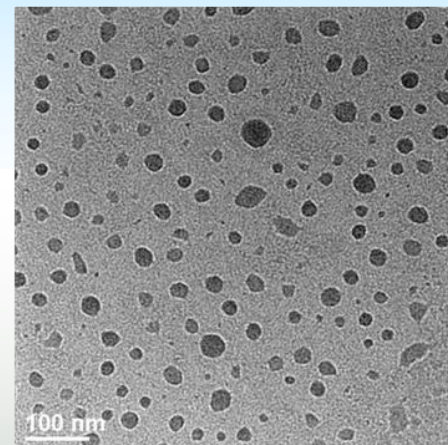
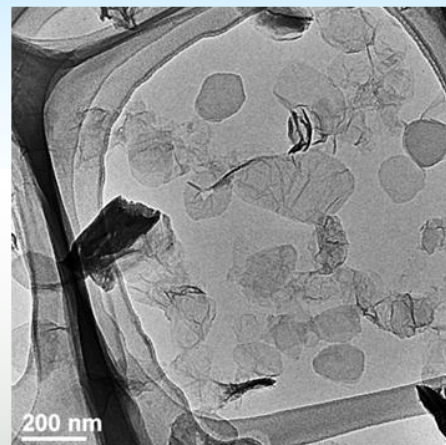
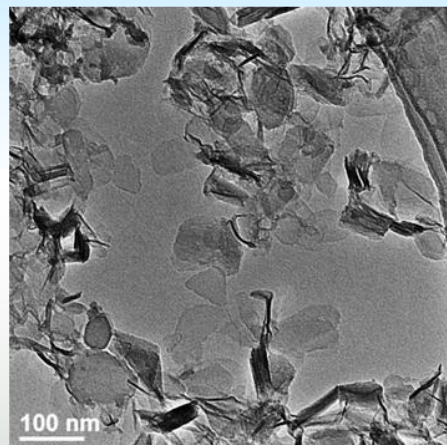
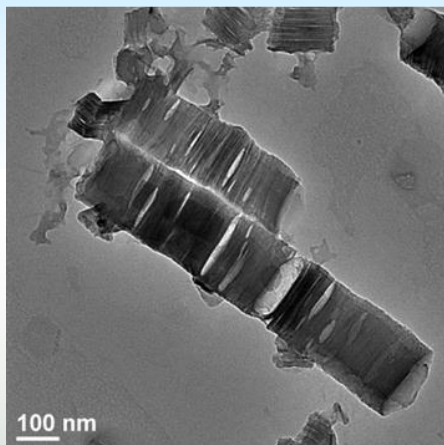
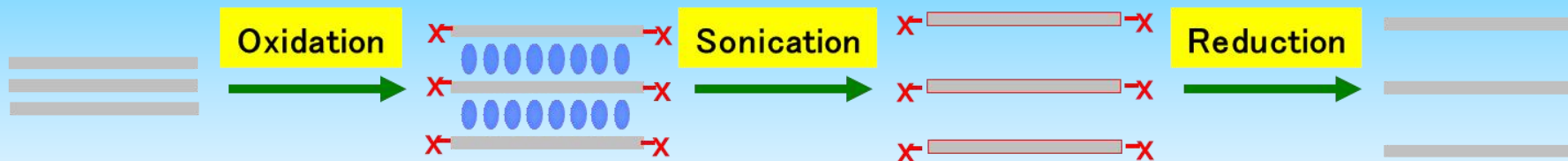

Nitrogen-Doped Graphenes by a Combined Chemical and Hydrothermal Reduction

Langmuir, 2010, 26 (20), pp 16096–16102

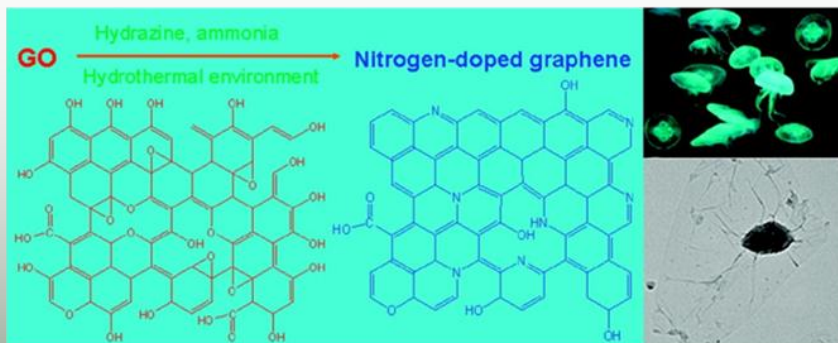
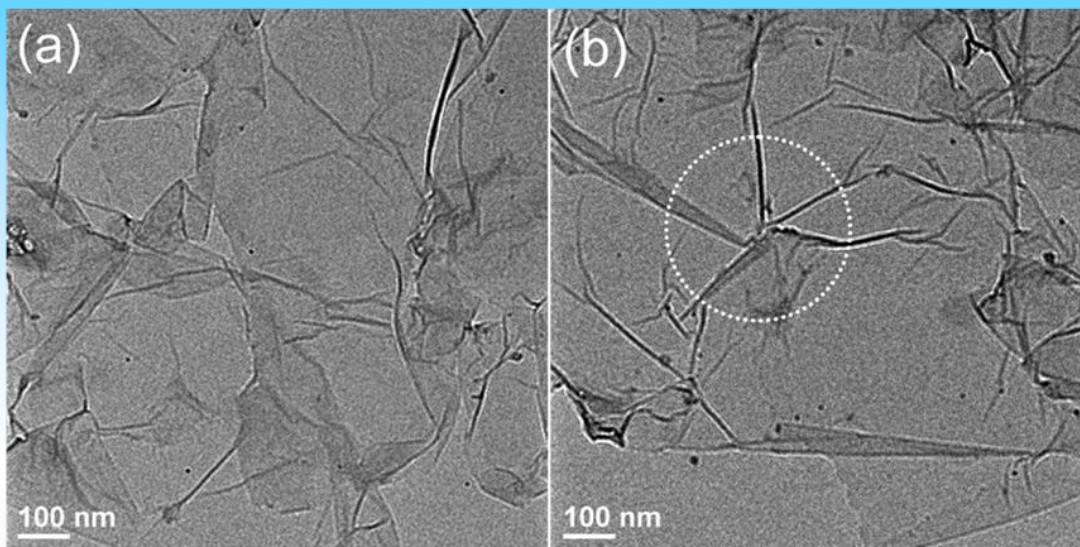
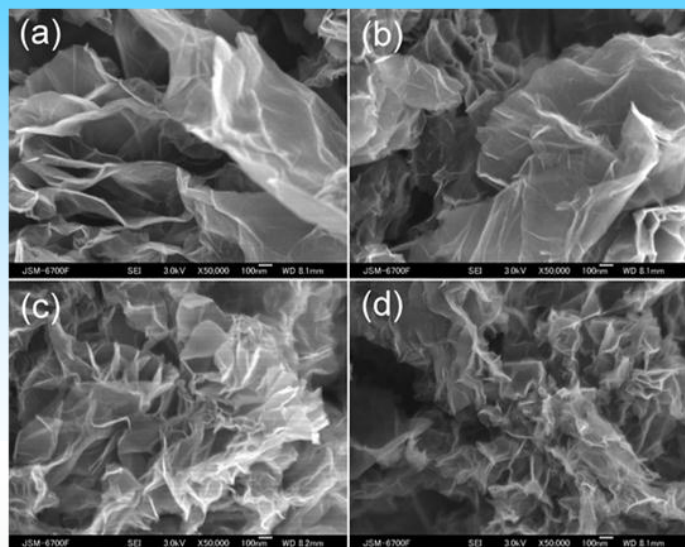

samples	C (wt %)	H (wt %)	N (wt %)	O ^a (wt %)	N/C (at./at.)	O/C (at./at.)
GO	49.59	2.28	0.03	48.05	0.0018	0.72
HR-80	80.43	1.23	5.21	13.13	0.074	0.12
HR-120	80.76	1.15	4.57	13.52	0.064	0.12
HR-160	84.15	1.15	4.09	10.61	0.055	0.091
HR-200	86.12	1.23	4.01	8.64	0.051	0.077

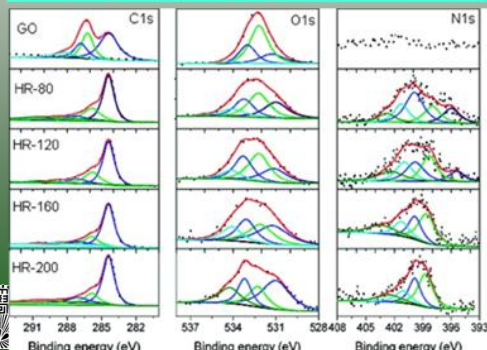

samples	N/C (at./at.)	O/C (at./at.)	N distribution (at. %)				
			395.7 ± 0.3 eV	398.7 ± 0.3 eV	400.3 ± 0.3 eV	401.4 ± 0.3 eV	402–405 eV
GO	0	0.45					
HR-80	0.11	0.16	16	18	37	18	11
HR-120	0.095	0.13	11	27	24	21	17
HR-160	0.071	0.13	0	39	25	17	19
HR-200	0.052	0.098	0	42	28	16	14

2. Preparation of mesoporous CNFs

Preparation of mesoporous HCNF and TCNF

From graphitized HCNF and TCNF (GHCNF and GTCNF)

GPCNF

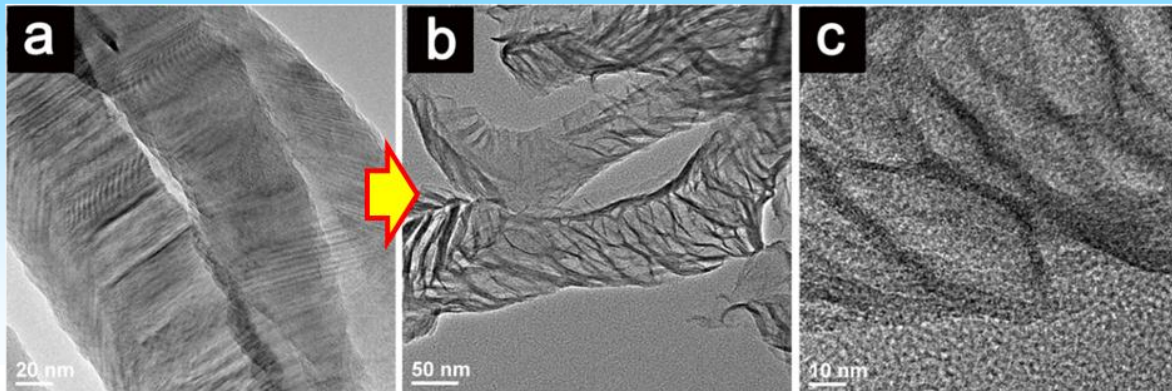
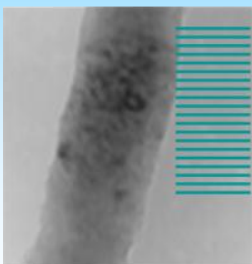

$$S_{\text{BET}} = 307 \text{ m}^2/\text{g}$$

GHCNF

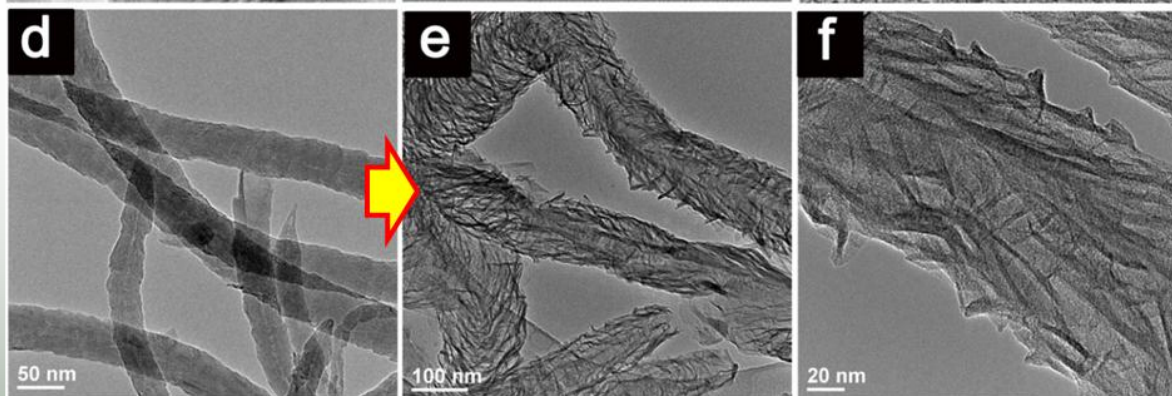
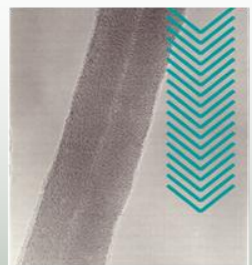

$$S_{\text{BET}} = 215 \text{ m}^2/\text{g}$$

GTCNF

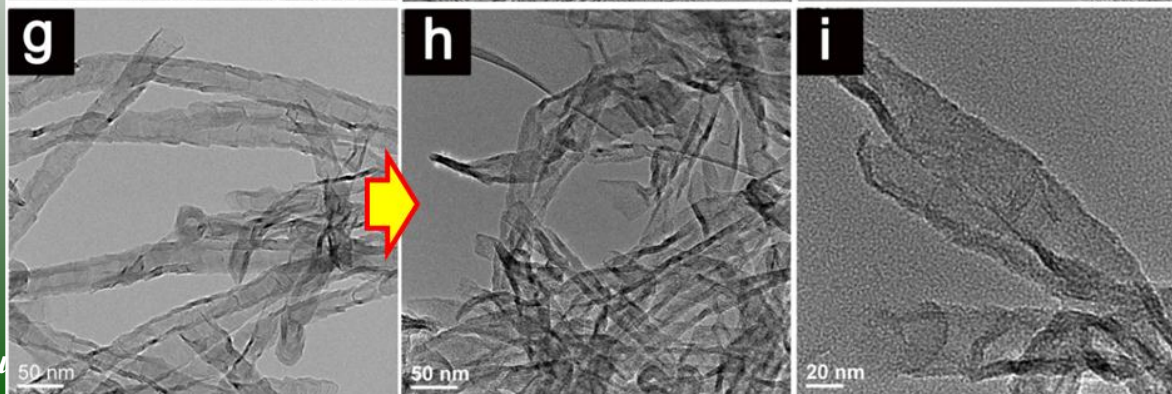

$$S_{\text{BET}} = 168 \text{ m}^2/\text{g}$$

4. Electrochemical applications

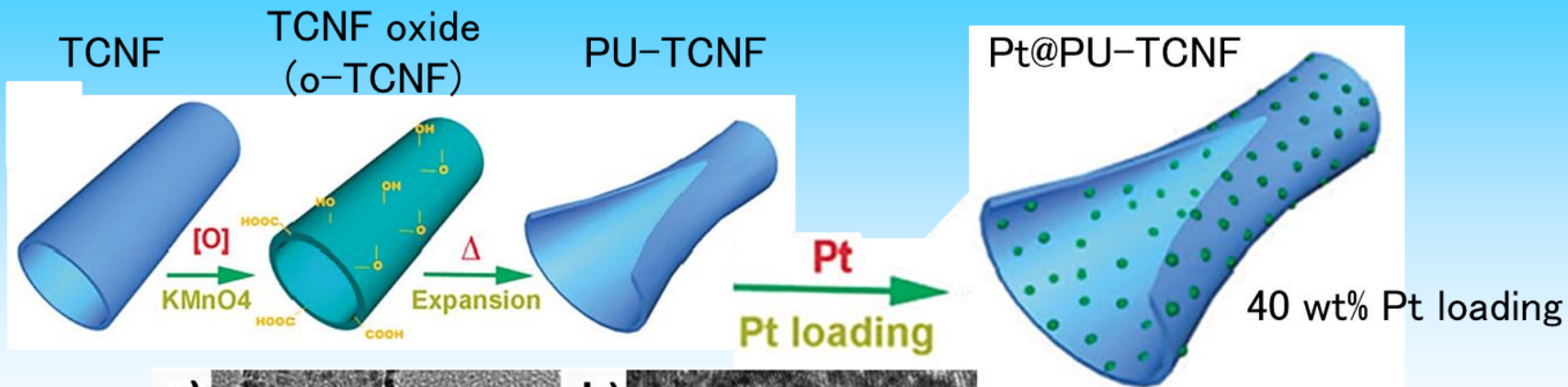

Pt@TCNF

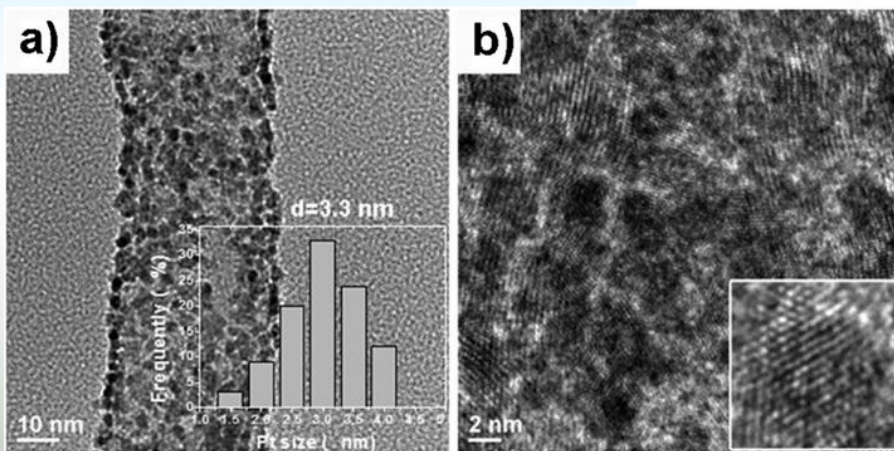

Pt@PU-TCNF

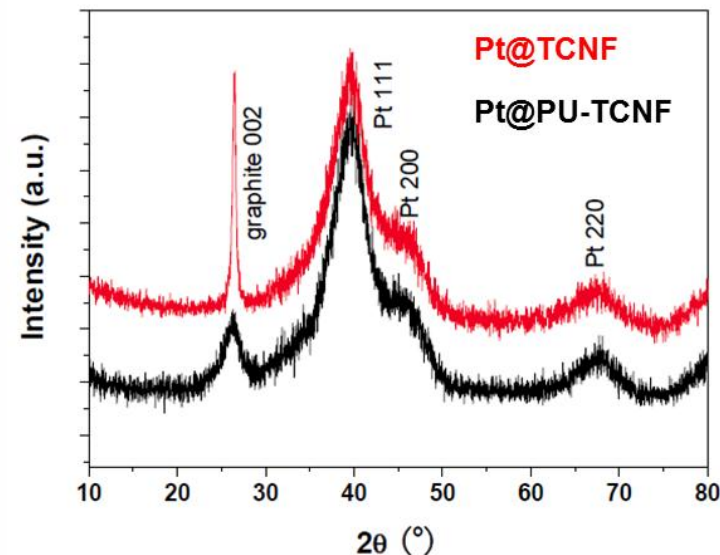
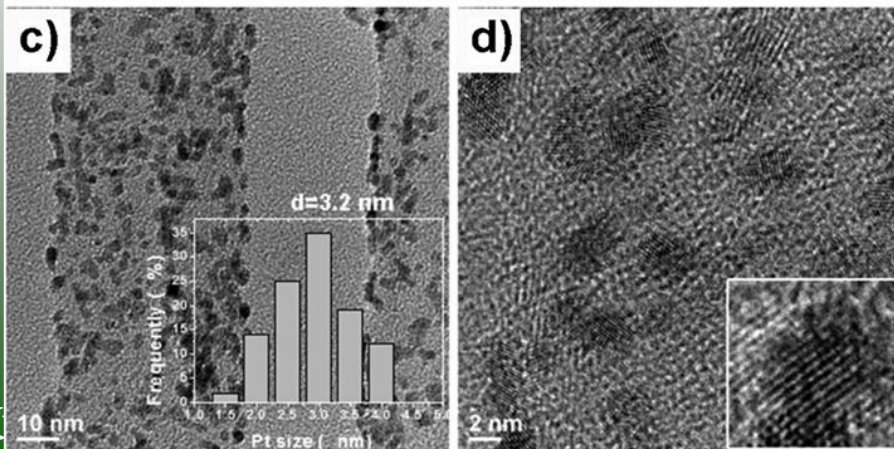

XRD patterns

→ $d(\text{avg.}) = 3.2$ nm



What is a functional Nano-material

Functional Material

Adsorption

Support

Electrode

Filler

etc.

Improvement of Functions by Growing CNFs

CNF
複合化

Function improvement
Function Hybridization
Novel Function Creation

Pretreatment of Surface

Catalyst supporting

CNF Growth

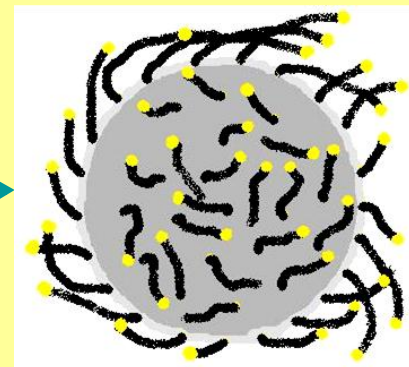
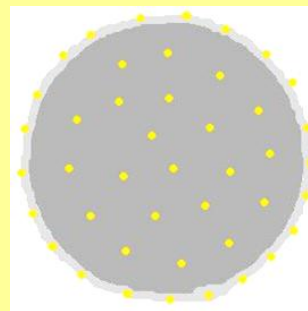
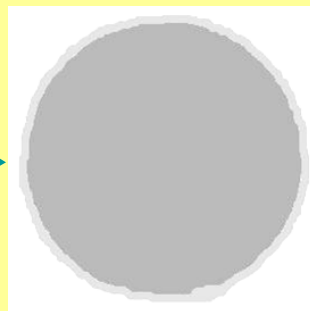
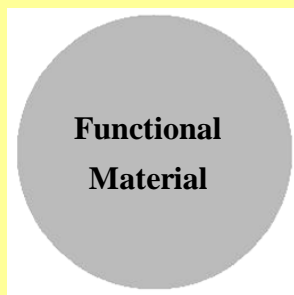

Various CNF Composites

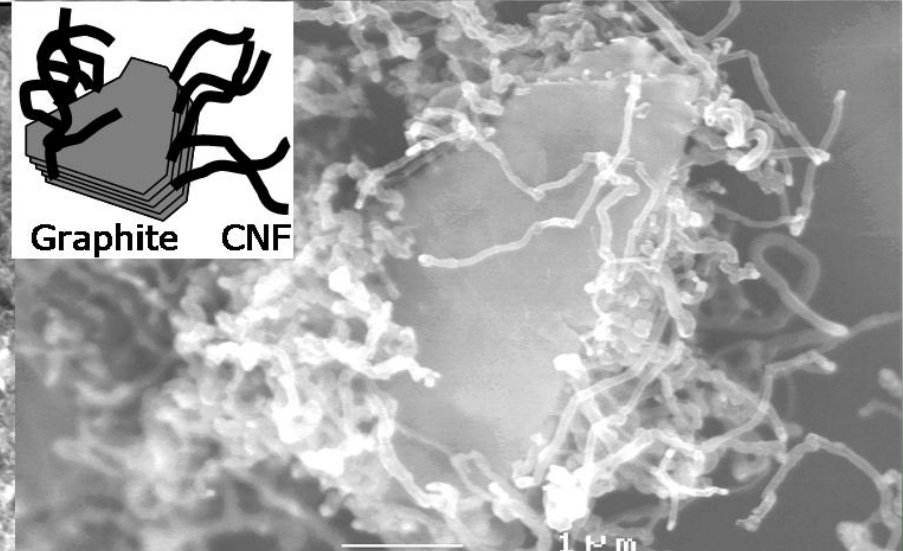
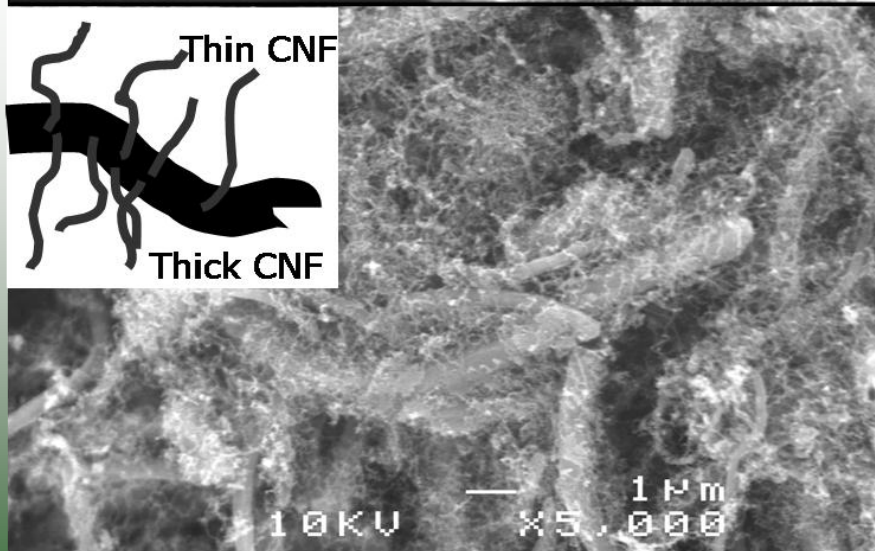
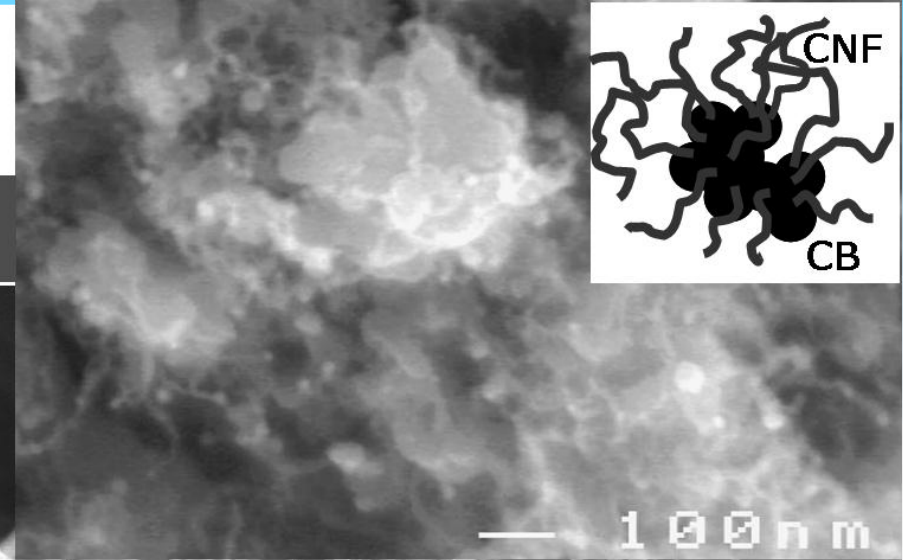
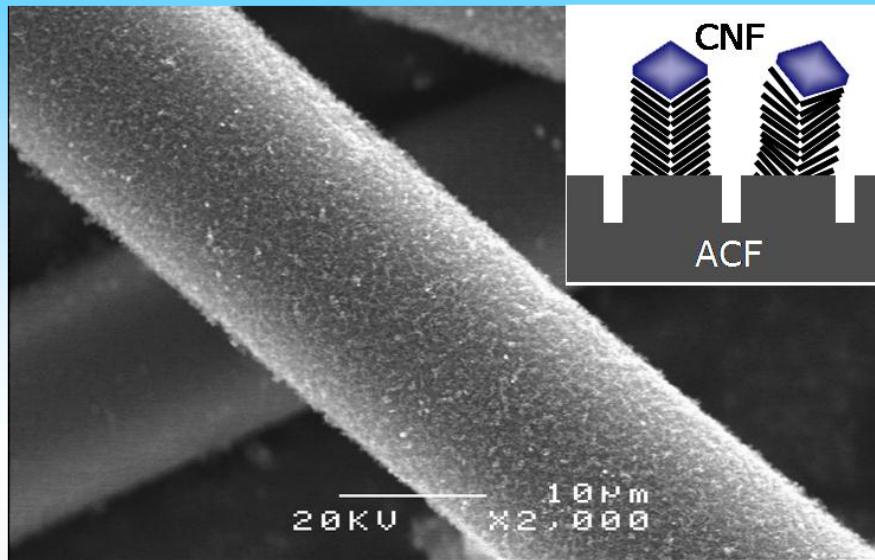

Pyrolytic carbon coated Si-CNF composite

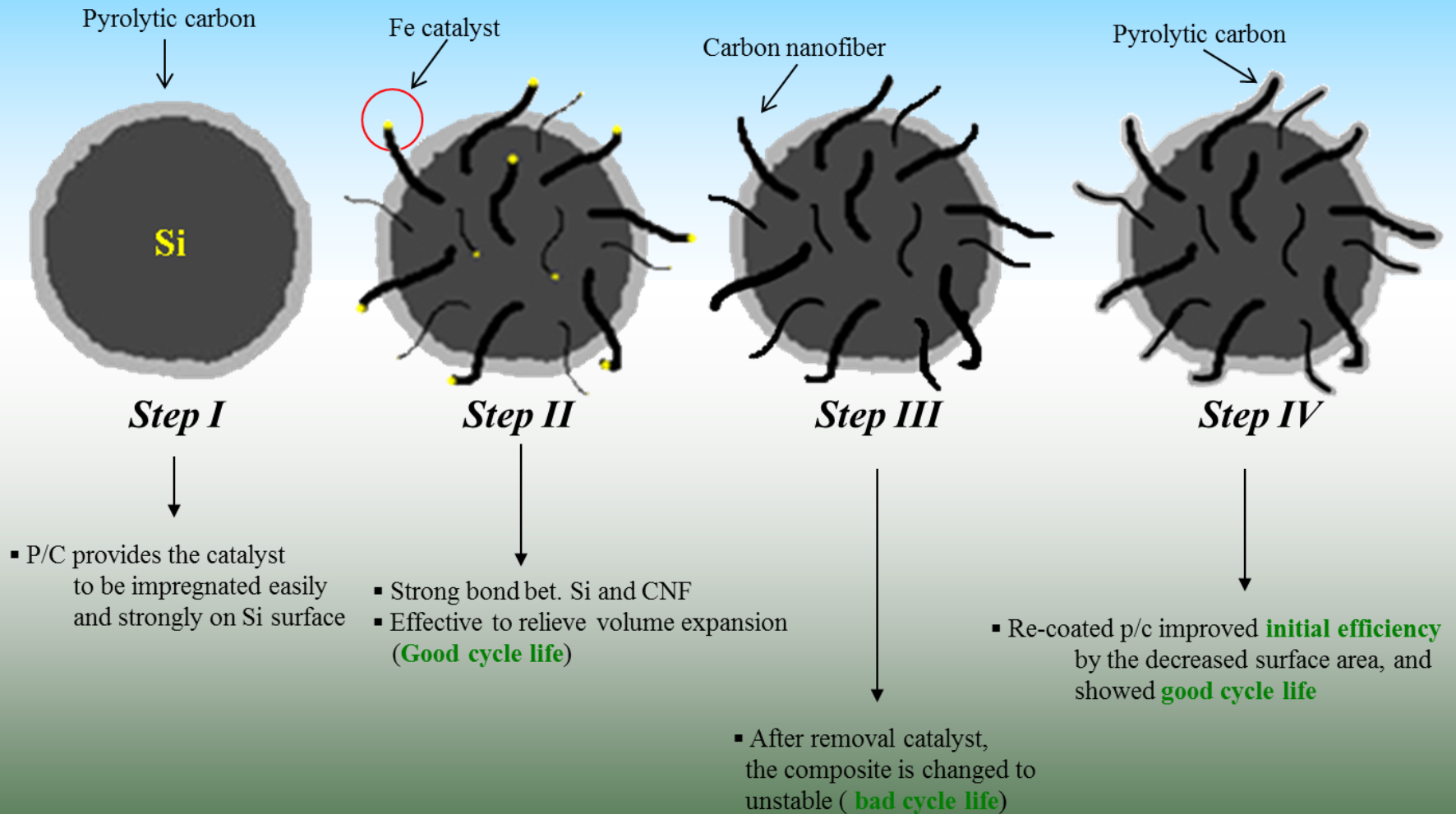

All of the p/c coated Si-CNF composite showed the improved reversible capacity and cycle lifes

Research scope of Yoon's Lab

- Outline and Interrelation of Research Topics

- Synthesis and applications of functional materials
- Energy and environmental engineering

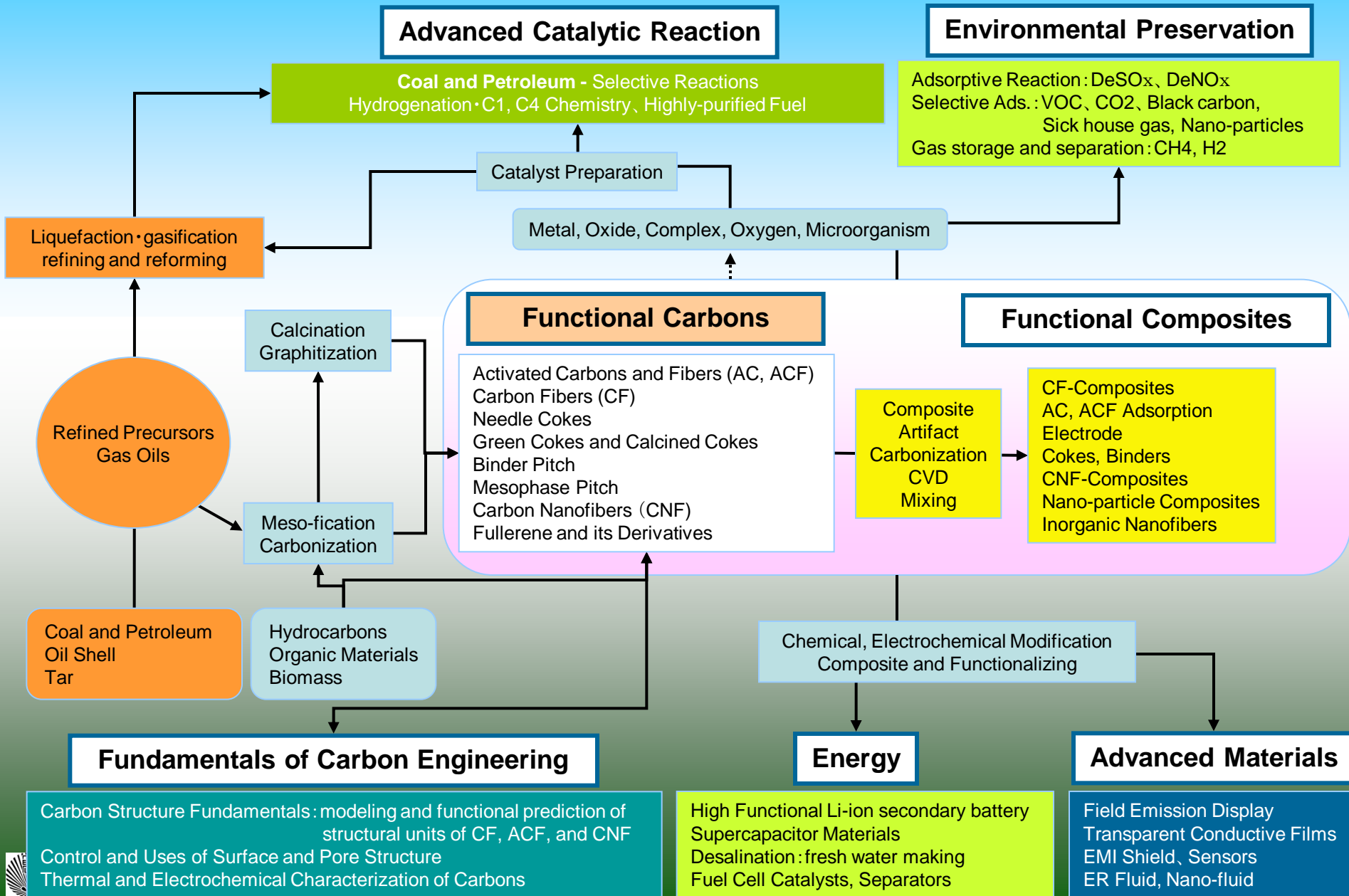

Effective Utilization of Coals and Biomass

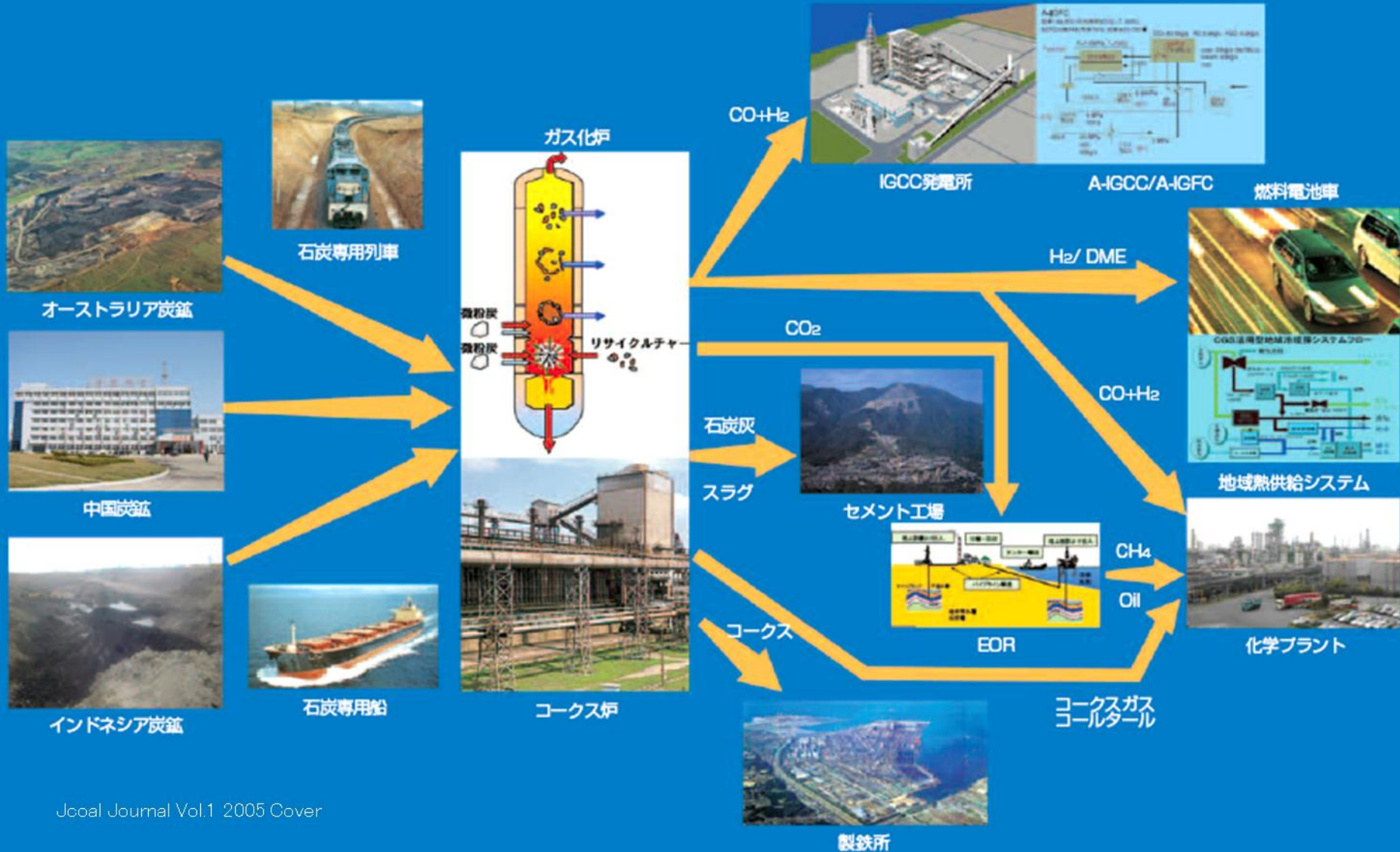

Stacked Structure of Catalyst for Petroleum

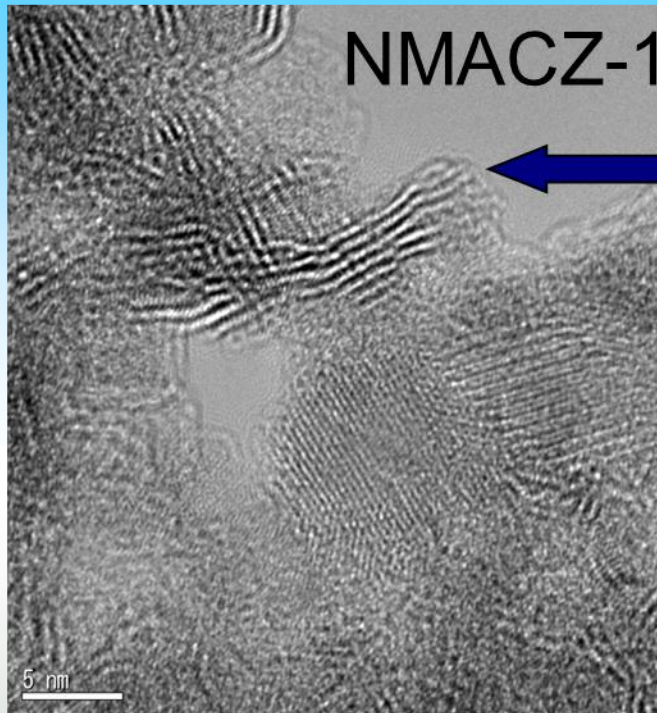

MoS₂ Average Stacking Layers ; 4-6

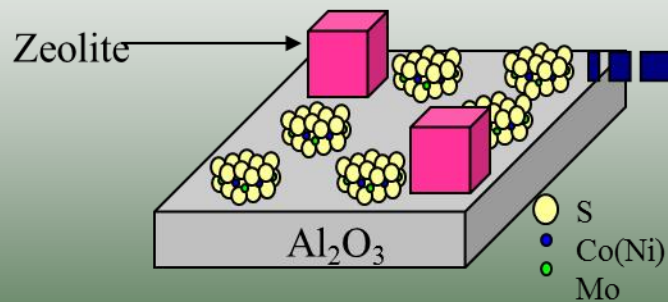
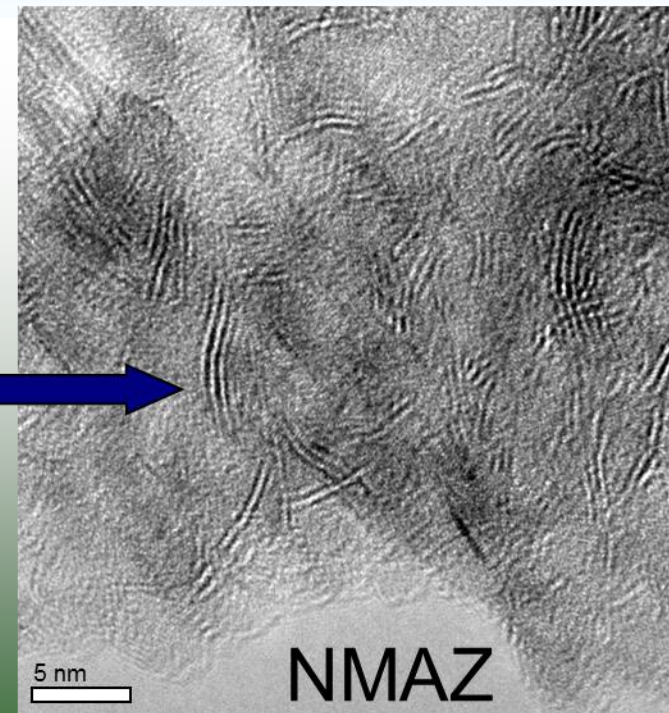
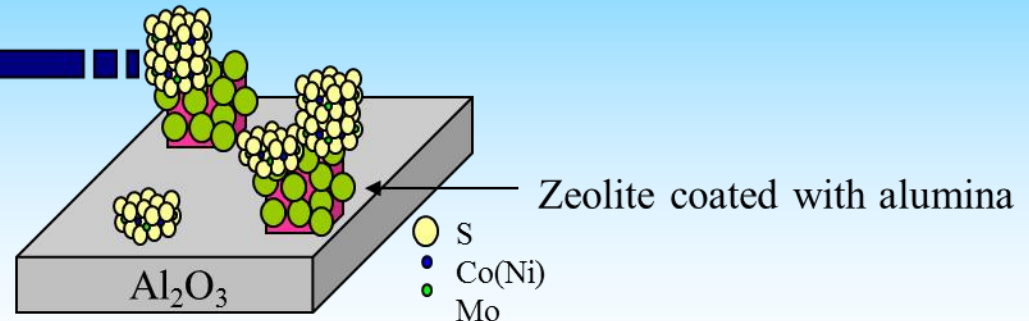

MoS₂ Average Stacking Layers ; 2-4

Carbons from now

Era of nano-carbons are almost finished. Only special applications are promising!

Era of GOOD Raw material to GOOD Product are almost finished. China and other developing countries will take over whole markets!

Era of BAD Raw material to GOOD Product are coming. Developed countries only have chances on such materials

Novel carbon, if it can be found, still has a chance to change the paradigm.
But what is that?

**Nano-carbons
(Concept, methodology)**

Fusion

**Conventional carbons
(Waste Materials)**

New carbon materials, New processes for manufacturing, New markets for carbon applications

New Carbonaceous Materials Technology

New feasible technology to solve urgent energy and environmental problems which fusion conventional fuel science, carbon technology and nano-carbon technology.

Fossil Fuel Science & Technology

- Petroleum Chemistry, Technology
- Coal & Biomass Sciences
- Catalyst, Mining

Conventional Carbon Technology

- Carbonaceous Materials Sciences
- Carbon Technology
- Carbon alloy science
- Activated carbon science



Nano Carbon Technology

- Nano structural concept
- Nano technologic method

Why New Carbon Technology through the fusion of Conventional and Nano Carbon Technologies ?

- **Innovation of performances of carbon materials.**
- **Consumption of fossil fuels grows by 2~3 times up to 2050.**
 - High utilizations of fossil fuels and biproducts,
 - Decreasing environmental burdens

Conclusion

- Carbon is Key Materials for Energy and Environmental Devices.
- High Utilization of Fossil Fuels and Their Bi-products is most urgent task to solve.
- New Structural Concept and Producing Method Can Increase the Industry Realization.
- Best Structure Must Be Selected For Each Objective and Prepared.
 - Preparation step (Selective and Controlled Synthesis)
 - Modifications



- It is time to re-innovate!

Report

1. **炭素材が省エネルギー・環境保全デバイスのKeyマテリアルになる理由を分子構造、物性の側面から記述せよ。
(半ページ程度)**
2. **比表面積を増やすにはどうすればよいか？
炭素材に細孔を導入する手法としてガス賦活(物理賦活)と薬品賦活(化学賦活)がある。それぞれを説明せよ。**

- **提出期限: 次の授業時間まで**
- **Word Processorを使わずに作成すること。**
- **A4 1枚で作成すること。**
- **授業日時と講義者(Yoon教授)を明記すること。**